



U.S. DEPARTMENT OF  
**ENERGY**

PNNL-18284

Prepared for the U.S. Department of Energy  
under Contract DE-AC05-76RL01830

# Production of Gasoline and Diesel from Biomass via Fast Pyrolysis, Hydrotreating and Hydrocracking: A Design Case

SB Jones	JE Holladay
C Valkenburg	DJ Stevens
C Walton	C Kinchin
DC Elliott	S Czernik

February 2009



**Pacific Northwest**  
NATIONAL LABORATORY

## DISCLAIMER

This report was prepared as an account of work sponsored by an agency of the United States Government. Neither the United States Government nor any agency thereof, nor Battelle Memorial Institute, nor any of their employees, makes **any warranty, express or implied, or assumes any legal liability or responsibility for the accuracy, completeness, or usefulness of any information, apparatus, product, or process disclosed, or represents that its use would not infringe privately owned rights.** Reference herein to any specific commercial product, process, or service by trade name, trademark, manufacturer, or otherwise does not necessarily constitute or imply its endorsement, recommendation, or favoring by the United States Government or any agency thereof, or Battelle Memorial Institute. The views and opinions of authors expressed herein do not necessarily state or reflect those of the United States Government or any agency thereof.

PACIFIC NORTHWEST NATIONAL LABORATORY  
*operated by*  
BATTELLE  
*for the*  
UNITED STATES DEPARTMENT OF ENERGY  
*under Contract DE-AC05-76RL01830*

**Printed in the United States of America**

**Available to DOE and DOE contractors from the  
Office of Scientific and Technical Information,  
P.O. Box 62, Oak Ridge, TN 37831-0062;  
ph: (865) 576-8401  
fax: (865) 576-5728  
email: [reports@adonis.osti.gov](mailto:reports@adonis.osti.gov)**

**Available to the public from the National Technical Information Service,  
U.S. Department of Commerce, 5285 Port Royal Rd., Springfield, VA 22161  
ph: (800) 553-6847  
fax: (703) 605-6900  
email: [orders@ntis.fedworld.gov](mailto:orders@ntis.fedworld.gov)  
online ordering: <http://www.ntis.gov/ordering.htm>**



This document was printed on recycled paper.

(9/2003)

# Production of Gasoline and Diesel from Biomass via Fast Pyrolysis, Hydrotreating and Hydrocracking: A Design Case

SB Jones<sup>1</sup>      JE Holladay<sup>1</sup>  
C Valkenburg<sup>1</sup>      DJ Stevens<sup>1</sup>  
C Walton<sup>1</sup>      C Kinchin<sup>2</sup>  
DC Elliott<sup>1</sup>      S Czernik<sup>2</sup>

February 2009

Prepared for  
the U.S. Department of Energy  
under Contract DE-AC05-76RL01830

Pacific Northwest National Laboratory  
Richland, Washington 99352

---

<sup>1</sup> Pacific Northwest National Laboratory

<sup>2</sup> National Renewable Energy Laboratory



## Executive Summary

The President has established a goal to supply 35 billion gallons per year of renewable and alternative fuels by 2017. This goal is addressed in part by the U.S. Department of Energy (DOE) Office of Biomass Program's (OBP's) Thermochemical Platform multiyear program plan to "convert biomass to fuels, chemicals and power via thermal and chemical processes such as gasification, pyrolysis and other non-biochemical processes" (DOE 2008).

In recent years, the Biomass Program completed technoeconomic evaluations of both biological and thermochemical pathways for converting biomass to ethanol. These "design case" studies provided a detailed basis for understanding the current state of various conversion technologies for producing fuel ethanol. The studies also helped identify technical barriers for which research and development could potentially lead to significant cost improvements. Consistent assumptions for items such as plant lifetimes, rates of return, and other factors were used in all cases so the various processes could be compared.

At present, the use of biomass resources to produce infrastructure-compatible fuels is appealing. Hydrocarbon biofuels can potentially be used without significant changes to the current fuel distribution and utilization infrastructure, including pipelines, pumping stations, and vehicles. Given the relatively short time between now and 2017, the goal of 35 billion gallons per year of renewable fuels will be more readily met if hydrocarbon biofuels are part of the fuel mix.

The purpose of this design case study is to evaluate a processing pathway for converting biomass into infrastructure-compatible hydrocarbon biofuels. This design case investigates production of fast pyrolysis oil from biomass and the upgrading of that bio-oil as a means for generating infrastructure-ready renewable gasoline and diesel fuels. Other options for pyrolytic processes and upgrading steps exist, but they were not evaluated in this study. Likewise, gasification pathways that could be used to produce hydrocarbons are not addressed here. This study has been conducted using the same methodology and underlying basis assumptions as the previous design cases for ethanol.

The overall concept and specific processing steps were selected because significant data on this approach exists in the public literature. The analysis evaluates technology that has been demonstrated at the laboratory scale or is in early stages of commercialization. The fast pyrolysis of biomass is already at an early stage of commercialization, while upgrading bio-oil to transportation fuels has only been demonstrated in the laboratory and at small engineering development scale. Advanced methods of pyrolysis, which are under development, are not evaluated in this study. These, may be the subject of subsequent analysis by OBP.

The plant is designed to use 2000 dry metric tons/day of hybrid poplar wood chips to produce 76 million gallons/year of gasoline and diesel. The processing steps include:

1. Feed drying and size reduction
2. Fast pyrolysis to a highly oxygenated liquid product
3. Hydrotreating of the fast pyrolysis oil to a stable hydrocarbon oil with less than 2% oxygen
4. Hydrocracking of the heavy portion of the stable hydrocarbon oil

5. Distillation of the hydrotreated and hydrocracked oil into gasoline and diesel fuel blendstocks
6. Hydrogen production to support the hydrotreater reactors.

Note that the Idaho National Laboratory (INL) is working on feedstock logistics that will eliminate the need for drying and size reduction at the plant. That is, the “as received” feedstock to the pyrolysis plant will be “reactor ready”. This development will likely further decrease the cost of producing the fuel.

The capital cost for a standalone “n<sup>th</sup>” plant is \$303 million (2007 basis). At a 10% return on investment (ROI), the minimum fuels (gasoline + diesel) selling price is \$2.04/gal (\$1.34/gal ethanol equivalent basis).

An important sensitivity is the possibility of co-locating the plant with an existing refinery. In this case, the plant consists only of the first three steps: feed prep, fast pyrolysis, and upgrading. Stabilized, upgraded pyrolysis oil is transferred to the refinery for separation and finishing into motor fuels. The off-gas from the hydrotreaters is also transferred to the refinery, and in return the refinery provides lower-cost hydrogen for the hydrotreaters. This reduces the capital investment to \$188 million and the minimum fuel selling price to \$1.74/gal (\$1.14/gal ethanol equivalent basis).

Production costs near \$2/gal (in 2007 dollars) and petroleum industry infrastructure-ready products make the production and upgrading of pyrolysis oil to hydrocarbon fuels an economically attractive source of renewable fuels. The study also identifies technical areas where additional research can potentially lead to further cost improvements.

## Acronyms and Abbreviations

AR	As received
Btu	British thermal units
CFB	circulating fluid beds
DOE	U.S. Department of Energy
gal	gallon
HDS	hydrodesulfurized
HTS	high temperature shift
LHV	lower heating value
MFSP	minimum fuel product selling price
MM	Million
mm	millimeter(s)
mtpd	metric tons per day
MWth	megawatts thermal
OBP	Office of the Biomass Program
PSA	pressure swing adsorption
ROI	return on investment
tpd	tons per day
TPEC	total purchased equipment cost



# Contents

Executive Summary .....	iii
Acronyms and Abbreviations .....	v
1.0 Introduction .....	1.1
2.0 Analysis Approach .....	2.1
3.0 Feedstock and Plant Size .....	3.1
4.0 Process Overview .....	4.1
4.1 Fast Pyrolysis Oil Upgrading .....	4.3
5.0 Process Design.....	5.4
5.1 Feed Handling and Fast Pyrolysis.....	5.4
5.2 Hydrotreating to Stable Oil .....	5.6
5.3 Hydrocracking and Product Separation.....	5.7
5.4 Hydrogen Production .....	5.8
5.5 Cooling Water and Utilities.....	5.9
5.6 Process Yields and Consumptions .....	5.10
6.0 Process Economics .....	6.1
6.1 Capital Costs .....	6.1
6.1.1 Pyrolysis Unit.....	6.1
6.1.2 Pyrolysis Oil Hydrotreating and Hydrocracking .....	6.1
6.1.3 Hydrogen Generation .....	6.2
6.1.4 Balance of Plant .....	6.2
6.2 Operating Costs.....	6.3
6.3 Minimum Fuel Selling Price .....	6.3
7.0 Economic and Technical Sensitivities .....	7.1
7.1 Co-location with a Refinery .....	7.1
7.2 Financial and Market Sensitivities .....	7.2
7.3 Research Sensitivities.....	7.3
8.0 Conclusions and Recommendations .....	8.1
9.0 References .....	9.1
Appendix A Design Case – Stand-Alone Heat and Material Balance .....	A.4
Appendix B Equipment Cost Details .....	B.1

# Figures

Figure 4.1. Block Diagram of Overall Design .....	4.1
Figure 4.2. Typical Product Yields from Different Modes of Wood Pyrolysis .....	4.2
Figure 5.1. Block Diagram of Fast Pyrolysis.....	5.4
Figure 5.2. Block Diagram of Bio-Oil Upgrading .....	5.6
Figure 5.3. Block Diagram of Hydrocracking and Product Separation .....	5.8
Figure 5.4. Block Diagram of Hydrogen Production.....	5.9
Figure 7.1. Block Diagram of Pyrolysis and Upgrading Plant Co-located with a Refinery .....	7.1
Figure 7.2. Financial/Market Sensitivities .....	7.3
Figure 7.3. Research Sensitivities .....	7.4

# Tables

Table 5.1. Feedstock and Processing Assumptions .....	5.5
Table 5.2. Product Characterization.....	5.5
Table 5.3. Hydrotreating Conditions.....	5.7
Table 5.4. Hydrotreating Product Yields .....	5.7
Table 5.5. Hydrocracking Conditions .....	5.8
Table 5.6. Process Water Demands .....	5.9
Table 5.7. Overall Yields and Consumption.....	5.10
Table 5.8. Carbon Balance.....	5.10
Table 6.1. Pyrolysis Unit Literature Capital Cost.....	6.1
Table 6.2. Total Project Investment Cost for the Design Case Stand-Alone Plant.....	6.2
Table 6.3. Total Project Investment Factors .....	6.2
Table 6.4. Operating Cost Assumptions .....	6.3
Table 6.5. Economic Parameters.....	6.4
Table 6.6. Project Economics for the Stand-Alone Design Case Plant.....	6.5
Table 7.1. Comparison of Integrated and Standalone Facilities .....	7.2

## 1.0 Introduction

The President has established a goal to supply 35 billion gallons per year of renewable and alternative fuels by 2017 (White House 2007). This goal is addressed in part by the U.S. Department of Energy (DOE) Office of the Biomass Program's (OBP's) Thermochemical Platform multiyear program plan to "convert biomass to fuels, chemicals and power via thermal and chemical processes such as gasification, pyrolysis, and other non-biochemical processes" (DOE 2008).

In recent years, the Biomass Program completed technoeconomic evaluations of both biological and thermochemical pathways for converting biomass to ethanol. These "design case" studies provided a detailed basis for understanding the current state of various conversion technologies for producing fuel ethanol. The studies also helped identify technical barriers where research and development could potentially lead to significant cost improvements. Consistent assumptions for items such as plant lifetimes, rates of return, and other factors were used in all cases so the various processes could be compared.

At present, the use of biomass resources to produce infrastructure-compatible fuels is appealing. Hydrocarbon biofuels can potentially be used without significant changes to the current fuel distribution and utilization infrastructure, including pipelines, pumping stations, and vehicles. Given the relatively short time before 2017, the goal of 35 billion gallons of renewable fuels will be more readily met if hydrocarbon biofuels are part of the fuel mix.

The purpose of this design case study is to evaluate a processing pathway for converting biomass into infrastructure-compatible hydrocarbon biofuels.

This design case investigates fast pyrolysis oil production from biomass and the upgrading of that bio-oil as a means for generating infrastructure-ready renewable gasoline and diesel fuels. The overall concept and specific processing steps were selected because significant data on this approach exist in the public literature. Other options for pyrolytic processes and upgrading steps exist, but they were not evaluated in this study. One example of alternative processing options is hydrothermal pyrolysis followed by other upgrading steps. Likewise, gasification pathways can be used to produce hydrocarbons, but those are also not addressed here. These and other options may be addressed in future studies.

The design case presented here represents a goal case targeting performance potentially available between now and 2015. This analysis evaluates technology that has been demonstrated at the laboratory scale or is in early stages of commercialization. The fast pyrolysis of biomass is already at an early stage of commercialization, while the upgrading of the bio-oil to transportation fuels has only been demonstrated in the laboratory and at small engineering development scale. As such, the analysis does not reflect the current state of commercially-available technology but includes advancements that are potentially achievable by 2015.

The study has been conducted using the same methodology and underlying basis assumptions as the previous design cases for ethanol. It allows a basis for comparison with other research and development projects targeting the DOE objectives and lastly, provides a benchmark for the status of the pyrolysis program.



## 2.0 Analysis Approach

The approach used is similar to that employed in previous conceptual process designs and associated design reports (Aden et al. 2002, Spath et al. 2005, Phillips et al. 2007). Process flow diagrams are based on literature information and research results; these data were then used to build a process model in CHEMCAD<sup>®</sup>, a commercial process flow sheeting software tool. The capital costs were taken from literature sources or were obtained from Aspen ICARUS<sup>™</sup> software after being sized using the CHEMCAD<sup>®</sup> heat and material balances. The capital and operating costs were assembled in a Microsoft Excel<sup>®</sup> spreadsheet. A discounted cash flow method was used to determine the minimum product selling price.



### **3.0 Feedstock and Plant Size**

The feedstock is hybrid poplar wood chips delivered at 50 wt% moisture. The feedstock cost is assumed to be \$50.7/bone dry metric ton, delivered. This report takes a conservative approach and assumes the same moisture level as was used in previous studies (Aden et al. 2002, Spath et al. 2005, Phillips et al. 2007) and that feedstock grinding and drying occur at the plant.

The plant capacity is 2000 metric tons/day (mtpd) of bone dry wood. The plant is assumed to be an established (“n<sup>th</sup>”) plant design, rather than a first of its kind.



## 4.0 Process Overview

A simplified block diagram of the overall design is given in Figure 4.1. The processing steps include:

1. Feed drying and size reduction
2. Fast pyrolysis to a highly oxygenated liquid product
3. Hydrotreating of the fast pyrolysis oil to a stable hydrocarbon oil with less than 2% oxygen
4. Hydrocracking of the heavy portion of the stable hydrocarbon oil
5. Distillation of the hydrotreated and hydrocracked oil into gasoline and diesel fuel blendstocks
6. Steam reforming of the process off-gas and supplemental natural gas to produce hydrogen for the hydrotreating and hydrocracking steps.

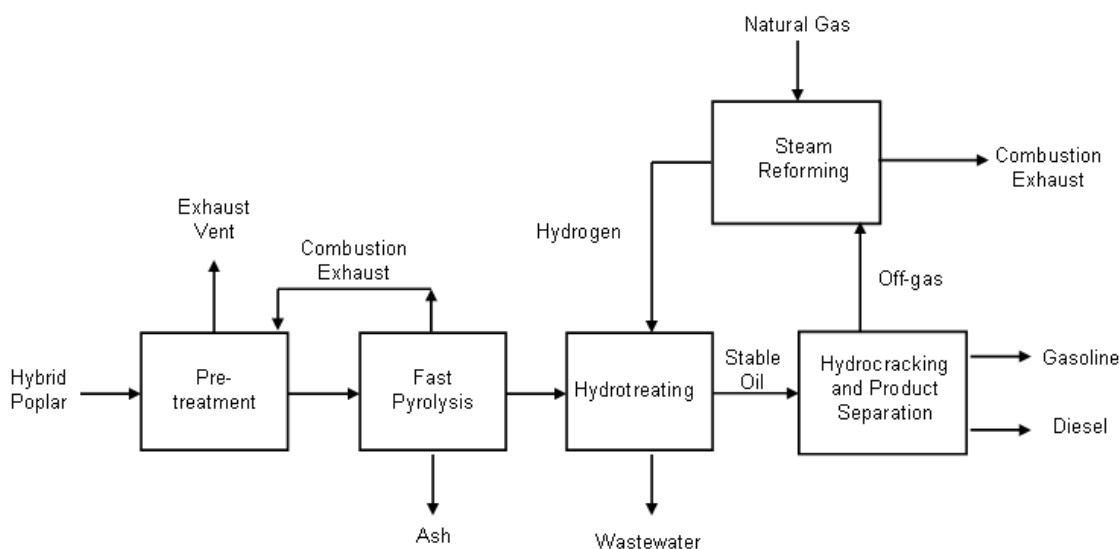
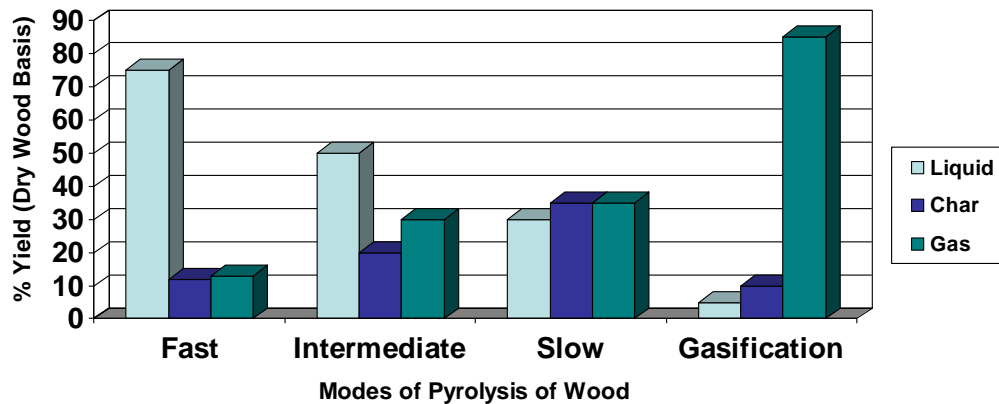

**Figure 4.1.** Block Diagram of Overall Design

**Feed Handling and Preparation:** The biomass feedstock is dried from its as-received moisture level to less than 10% to minimize water in the fast pyrolysis product liquid. It is then ground to 2-6 mm particle size to yield sufficiently small particles, ensuring rapid reaction in the pyrolysis reactor.

**Fast Pyrolysis:** Pyrolysis is the thermal decomposition of carbonaceous material in the absence of oxygen to produce char, gas, and a liquid product rich in oxygenated hydrocarbons. In general, pyrolysis is performed using a range of temperatures and residence times to optimize the desired product. Figure 4.2 illustrates the approximate yields from different modes of pyrolysis (Bridgewater 2007).

Fast pyrolysis is assumed in this work. The biomass is heated to approximately 500°C in less than 1 second, and then rapidly cooled to stop the reaction. The liquid product, known as bio-oil, is obtained in yields up to 75% by weight on a dry feed basis. It can also be upgraded to lower the oxygen content and transported using the same trillion-dollar infrastructure used by the oil industry. In addition to being transported and stored at a lower cost than solid biomass, bio-oil and upgraded oil can be used in applications ranging from value-added chemicals to transportation fuels.



**Figure 4.2.** Typical Product Yields from Different Modes of Wood Pyrolysis

There are many types of pyrolysis reactor configurations, each with different advantages and disadvantages. The following paragraphs summarize the various reactor types:

- *Ablative pyrolysis:* Mechanical pressure is used to press carbonaceous material (usually wood) against a heated reactor wall. Material in contact with the wall essentially “melts” and, as it is moved away, the residual oil evaporates as pyrolysis vapors. There is no requirement for inert gas in this configuration, so processing equipment (on demonstration scales) can be smaller and potentially less expensive. The other advantage to this configuration is that feed materials do not require extensive grinding to achieve particle sizes sufficient for high heating rates. Conversely, this configuration is surface-area controlled so scaling is a linear function of the heat-transfer area and does not benefit from the same economies of scale as the other systems. The system is also slightly more complex due to the mechanical nature of the process. There is currently a 50 tpd demonstration plant using this technology in Germany. (Bridgewater 2007)
- *Moving Bed or Auger Pyrolysis:* This reactor utilizes a screw to mix hot sand and biomass. While it provides good control of residence times and does not dilute the products with fluidizing gas, the sand must be reheated separately, which leads to mechanical reliability issues. There are currently no large-scale commercial plants. (Bridgewater 2007)
- *Entrained Flow Pyrolysis:* This reactor configuration is popular for studies of thermochemical conversion kinetics and investigations of the effects of pressure. Feed material is typically fed into the top of the reactor, co-current with a gas stream. The flow through this configuration is assumed to approximate plug flow, with the residence time controlled by the length of the heated zone. Char buildup can be a troublesome trade-off for these simple and inexpensive reactors. Liquid yields are usually lower than fluid bed systems. (Bridgewater 2007)
- *Rotating Cone:* This reactor combines biomass and hot sand at the top of the vessel. The solids are mixed by a rotating cone inside the vessel. Hot pyrolysis oil vapors leave near the bottom of the reactor, while hot sand and char exit the reactor from the bottom of the cone. No carrier gas is needed, resulting in smaller downstream equipment. A 2 mtpd plant operating on palm oil empty fruit bunches was commissioned in Malaysia in 2006. (BTG 2009)
- *Bubbling Fluidized Bed Pyrolysis:* Here, biomass is introduced to hot sand fluidized by recirculated product gas. This technology is well understood, simple to construct and operate (on large scales), and very efficient in transferring heat to the biomass, resulting in high liquid yields. Small biomass

particle sizes are required for this method in order to obtain high heating rates. Dynamotive currently operates two plants, one 100 mtpd and one 200 mtpd, in Canada. (Bridgewater 2007, Dynamotive 2007)

- *Circulating Fluidized Bed Pyrolysis*: Similar to bubbling fluidized beds, these configurations circulate hot sand between the pyrolysis reactor and a sand re-heater. Char or product gas and char are burned to provide heat to the sand re-heater. Circulating fluid beds (CFBs) are widely used at very high throughputs in the petroleum industry and are potentially suitable for large biomass throughputs as well. Ensyn operates a 100 tpd (200 tpd green wood) plant in Canada. (Bridgewater 2007, Ensyn 2009)

Both fluidized bed configurations allow for greater control of vapor residence time, an important consideration for optimization of the high liquid yield associated with fast pyrolysis. A circulating fluidized bed was chosen, as this design is the most likely to be scalable to the 2000 mtpd feed rate assumed in this report.

## 4.1 Fast Pyrolysis Oil Upgrading

Untreated bio-oil is a dark brown, free-flowing liquid with about 25% water that cannot be easily separated. It is a complex mixture of oxygenated compounds that is unstable in long-term storage (Oasmaa and Kuoppala 2003, Diebold 2000) and is not miscible with any conventional hydrocarbon-based fuel (Bridgewater 2007). Bio-oil can be stabilized and converted to a conventional hydrocarbon fuel by removing the oxygen through hydrotreating. Hydrotreating to remove nitrogen and sulfur from hydrocarbons is a common and well established refinery process. Oxygen removal on the scale needed to upgrade pyrolysis oil is relatively new and is in the research stages.

The upgrading step involves contacting the bio-oil with hydrogen under pressure and at moderate temperatures (<400°C or 750°F) over fixed bed reactors. Single stage-hydrotreating has proved to be difficult, producing a heavy, tar-like product. Dual-stage processing, where mild hydrotreating is followed by more severe hydrotreating has been found to overcome the reactivity of the bio-oil (Elliot 2007). Overall, the pyrolysis oil is almost completely deoxygenated by a combination of hydrodeoxygenation and decarboxylation:

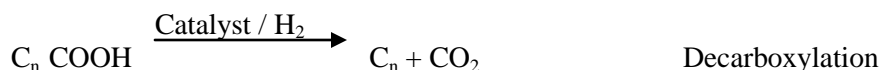
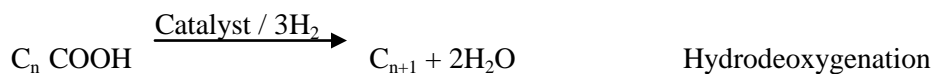

Less than 2% oxygen remains in the treated, stable oil. Water and off-gas are produced as byproducts. The water phase contains some dissolved organics, while the off-gas contains light hydrocarbons, excess hydrogen, and carbon dioxide.

Once stabilized oil is produced it can be further processed into conventional fuels or sent to a refinery. Both options are considered in this report.

## 5.0 Process Design

The design case assumes a standalone unit that combines feed pretreatment, fast pyrolysis, hydrotreating and hydrocracking of pyrolysis oil and separation to gasoline and diesel fuel blendstocks, and hydrogen generation.

### 5.1 Feed Handling and Fast Pyrolysis

Figure 5.1 shows the block diagram for the feed pretreatment, fast pyrolysis, and bio-oil quenching area. Hybrid poplar is dried from its 'as received (AR)' moisture level of 50 wt% to 7 wt% water using hot flue gases from the char combustor in a direct-contact dryer. It is then ground to approximately 2-6 mm.

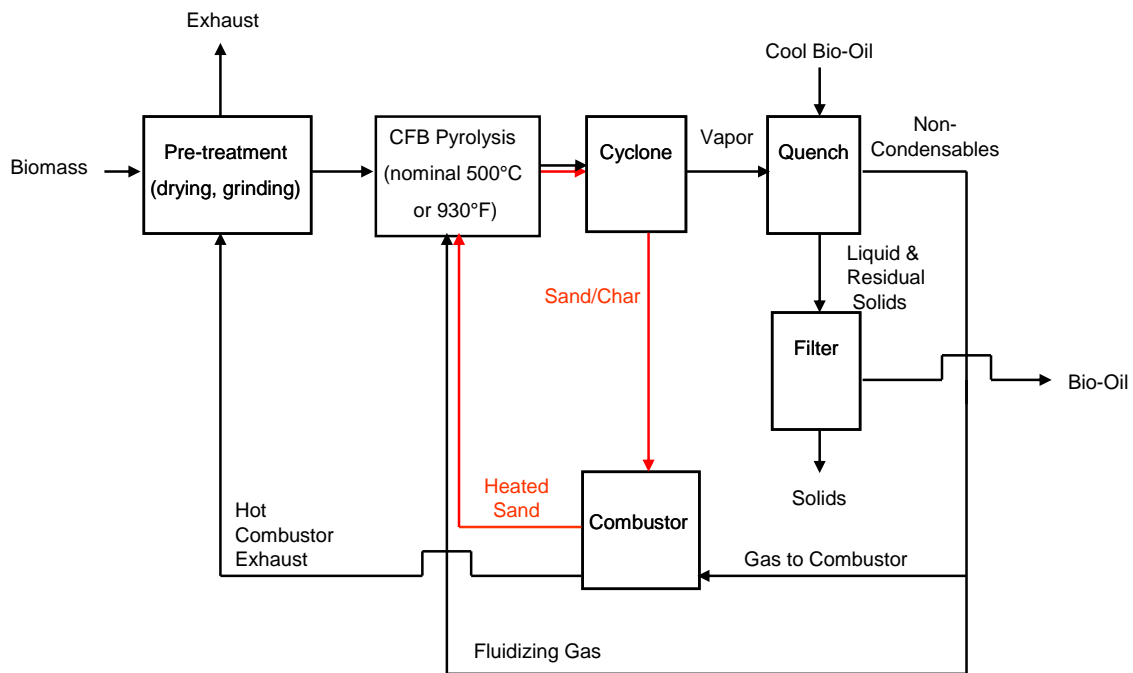

**Figure 5.1.** Block Diagram of Fast Pyrolysis

Table 5.1 summarizes the as received feedstock characteristics and feed requirements.

The dried, finely ground biomass is fed to a circulating fluidized pyrolysis reactor operating at 520°C. Sand is used as the fluidizing medium and the residence time is less than a second. The biomass is converted into a mixture of gases, bio-oil, and char. A cyclone separates the sand and char from the gases and liquids. The hot bio-oil vapor is rapidly quenched with cooled bio-oil and then separated from the remaining vapors (Solantausta 2003, Freel and Graham 1995). High temperature heat recovery is not included due to the likelihood of severe fouling in the recuperators (Johnson et al. 2006). Most of the gases are recycled back to the pyrolysis reactor to assist fluidization. The char and a portion of the gas are burned to heat the circulating sand. The cooled pyrolysis oil contains about 20-25% associated water.

Table 5.2 shows the product characterization. Note that the bio-oil yield is near the high end of the references. This choice is based on the assumption that improvements in bio-oil yield can be achieved by the 2015 time-frame.

**Table 5.1.** Feedstock and Processing Assumptions

	Assumed Value
Hybrid Poplar Wood Chips	
AR Moisture, wt%	50%
wt% Carbon (dry)	50.60 <sup>(a)</sup>
wt% Hydrogen (dry)	6.08 <sup>(a)</sup>
wt% Oxygen (dry)	40.75 <sup>(a)</sup>
wt% Nitrogen (dry)	0.61 <sup>(a)</sup>
wt% Sulfur (dry)	0.02 <sup>(a)</sup>
wt% Chlorine (dry)	0.01 <sup>(a)</sup>
wt% Ash (dry)	1.93 <sup>(a)</sup>
HHV, Btu/lb	8405 <sup>(a)</sup>
Temperature, °F (°C)	968 (520) <sup>(b)</sup>
Pressure	atmospheric <sup>(b)</sup>
Feed Moisture to pyrolysis unit, wt%	7 <sup>(b)</sup>
(a) Hybrid Poplar. Phyllis Database for Biomass and Waste	
(b) Solantausta 2003	

**Table 5.2.** Product Characterization

	Model Results	Reference Data <sup>(a)</sup>	Reference Data <sup>(b)</sup>
Yields, lb/100 lb dry wood			
Oil	65	59.9	66
Water	10	10.8	12
Char & Ash	13	16.2	8
Gas	12	13.1	11
Loss			3
Oil Composition			
Water in oil, wt%	21	15-30	
Carbon, wt% dry	58	55-58	
Hydrogen, wt% dry	6	5.5-7.0	
Oxygen, wt% dry	36	35-40	

(a) Ringer et al. 2006

(b) Mohan et al. 2006

The detailed model flowsheet diagram and associated heat and material balance for the fast pyrolysis section can be found in Appendix A.

## 5.2 Hydrotreating to Stable Oil

The simplified flow diagram for the stand-alone upgrading portion of the plant is shown in Figure 5.2.

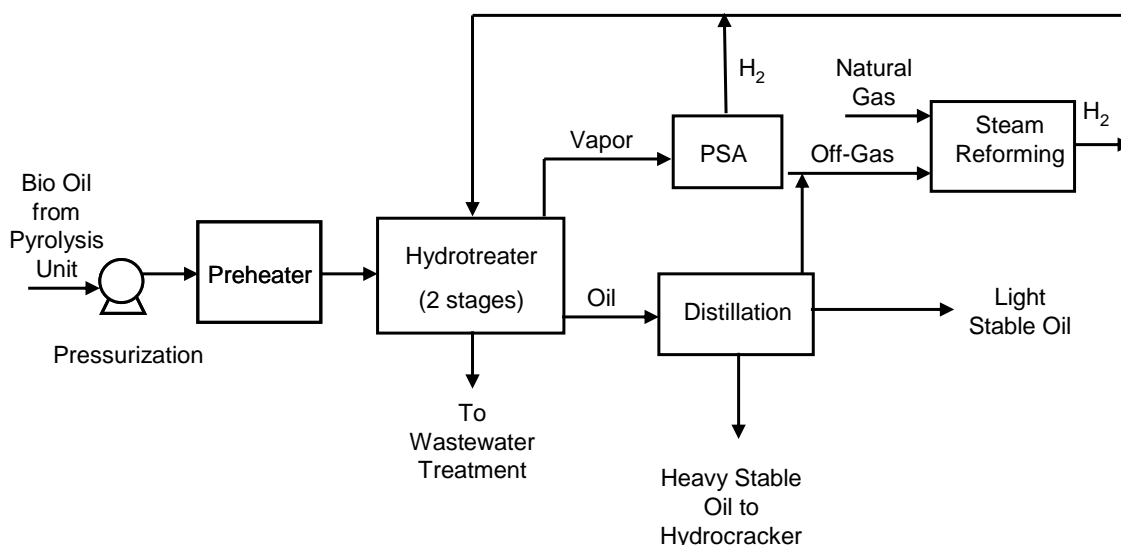

**Figure 5.2.** Block Diagram of Bio-Oil Upgrading

The filtered bio-oil product from the pyrolysis unit is pumped to high pressure, then combined with compressed hydrogen and preheated with reactor effluent. Two catalytic reaction stages are used. The first stage catalytic reactor serves to stabilize the bio-oil by mild hydrotreatment over cobalt molybdenum (CoMo) hydrotreating catalyst (Elliott 2007). The product oil is further processed in the second-stage hydrotreater. The second stage hydrotreater operates at higher temperature and lower space velocity than the first stage. CoMo catalyst is also used in this reactor. Reactor effluent and a fired heater provide feed preheat for the second stage. The second-stage product is separated into product oil, wastewater, and off-gas streams.

The off-gas from the hydrotreaters is sent to a Pressure Swing Adsorption (PSA) system for recovery of the hydrogen gas. The recovered hydrogen is recycled back to the reactors. The low pressure PSA tail gas stream, which is rich in byproduct light hydrocarbons, is sent to the steam reformer for hydrogen production. A small portion of this off-gas is used in the fired heater that preheats feed for the second-stage hydrotreater.

Anaerobic digestion can be used to treat the less than 2% organics in the wastewater.

The processing conditions are listed in Table 5.3. The product oil is a mixture of hydrocarbons with a low level (~2%) of oxygen, as shown in Table 5.4. Data from Beckman et al. (1990) and Elliot (2007) were used to estimate the product slate.

**Table 5.3. Hydrotreating Conditions**

	1 <sup>st</sup> Stage <sup>(a)</sup>	2 <sup>nd</sup> Stage <sup>(a)</sup>
Temperature, °F (°C)	465 (240)	700 (370)
Pressure, psig	2500	2015
LHSV, v/h/v	1	0.14

(a) Beckman et al 1990

**Table 5.4. Hydrotreating Product Yields**

	Model	Reference Data <sup>(a)</sup>	Reference Data <sup>(b)</sup>
Yields, lb /100 lb wet pyrolysis oil			
Stable Oil (Stream 304)	44		38
Water (Stream 230)	48		50
Gas (Streams 270 and 302)	13		12 by difference
Chemical H <sub>2</sub> Consumption, lb/100 lb dry oil	4.96	5.01	3.45
Stable Oil Composition (Stream 304)			
Water, ppm	0	50	0
Aromatics, wt%		10.0	Not reported
Carbon, wt% dry	88.1	86.8	86.8
Hydrogen, wt% dry	10.5	13.2	10.8
Oxygen, wt% dry	1.5	0.02	2.5
Specific Gravity	0.87	0.83	0.93
Btu/lb, gross	17,600	19,765	17,302
Btu/lb, net	16,600	18,525	16,276

(a) Tables 15 & 16 in Elliot 2007  
(b) Beckman et al. 1990, Chapter 5

### 5.3 Hydrocracking and Product Separation

Figure 5.3 shows the simplified flow diagram for the hydrocracking and product separations areas. The hydrotreated oil is stabilized by removing the butane and lighter components in a lights removal column. The stable oil stream is then separated into light and heavy fractions. The heavy fraction (which boils above 350°C (662°F) is sent to the hydrocracker to completely convert the oil to gasoline and diesel blend components.

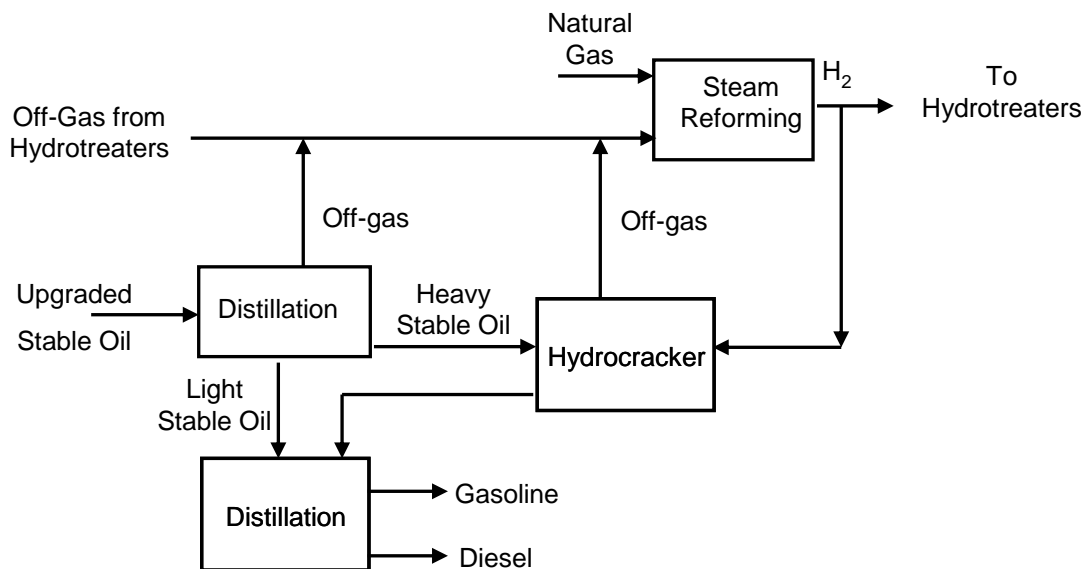

**Figure 5.3.** Block Diagram of Hydrocracking and Product Separation

The product is a mixture of liquids spanning the gasoline and diesel range and some byproduct gas. The gasoline and diesel range products are separated by distillation. These products are suitable for blending into finished fuel. The hydrocracking conditions and product yields are shown in Table 5.5.

**Table 5.5.** Hydrocracking Conditions

	Model	Reference Data
Nominal Temperature, °F (°C)	800 (427)	775 (413) <sup>(a)</sup>
Pressure, psig	1280	1051 (mild) – 2400 (resid) <sup>(a)</sup>
Gasoline, lb/100 lb feed	95	Depends on feed/conditions <sup>(a,b)</sup>
Diesel, lb/100 lb feed	5	Depends on feed/conditions <sup>(a,b)</sup>

(a) Parkash 2003  
(b) Gulf 2006

## 5.4 Hydrogen Production

Figure 5.4 shows the simplified flow scheme for hydrogen generation by steam reforming of natural gas (SRI International 2007, Meyers 2004) and the off-gas streams from the hydrotreating and hydrocracking processes. The off-gas by itself is insufficient to produce the amount of hydrogen required by the hydrotreaters and hydrocrackers; supplemental natural gas is required. Most of the off-gas is used to fire the reformer; however, a portion of the off-gas is compressed and mixed with makeup natural gas which is then hydrodesulfurized (HDS). Hydrogen for the HDS unit is supplied by the off-gas stream. The gas exiting the HDS is then mixed with superheated steam and sent to the steam reformer to produce syngas. The syngas hydrogen content is increased by high temperature shift (HTS). After condensing out the water, the hydrogen is purified by pressure swing adsorption (PSA). Off-gas from the PSA is recycled to the reformer burners.

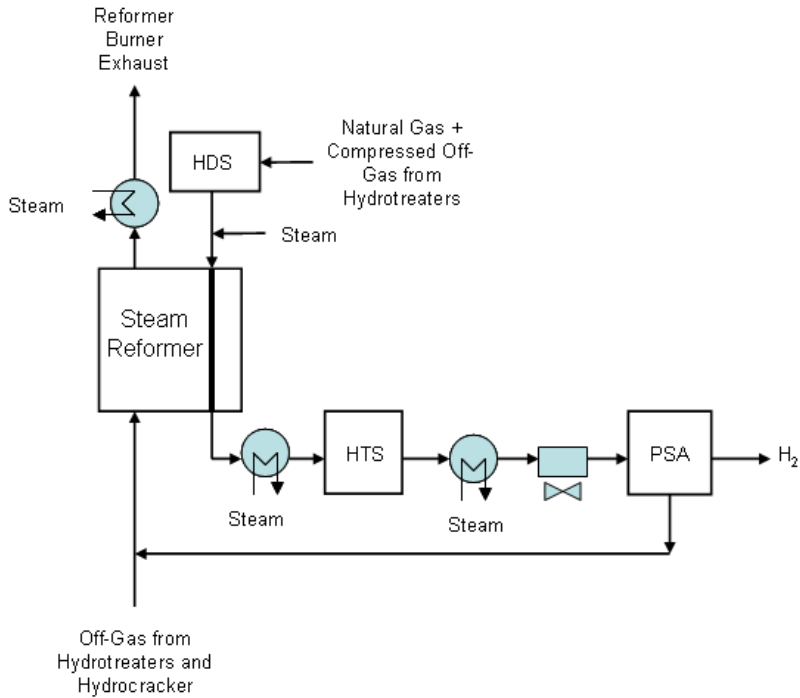

**Figure 5.4.** Block Diagram of Hydrogen Production

Saturated and superheated steam are generated by recuperating heat from the reformer exhaust and during syngas cooling. The steam is used to provide steam to the reformer and heat for process heaters and distillation column reboilers. A steam export credit is taken for the small amount of excess steam not used by the process. The heat and material balance for the steam reformer can be found in Appendix A.

## 5.5 Cooling Water and Utilities

Cooling water usage is minimized through the use of air fin coolers where applicable. The process water demands are shown in Table 5.6. Most of the cooling tower water is used to indirectly cool the fast pyrolysis bio-oil that is recirculated in the quench system. Optimizing the quench process could reduce this value further. For example, chillers could supply some of the cooling, however this would increase the power demand. Electricity is bought from the grid; no power is generated onsite. Waste water is treated in an onsite facility before discharge.

**Table 5.6.** Process Water Demands

Source of Water Demand	Model
Cooling tower makeup, gpm	373
Steam reformer boiler feed water makeup, gpm	113
Total, gpm	486
Overall demand, gal water/gal product	3.0

## 5.6 Process Yields and Consumptions

The yield of product fuel from wood is shown in Table 5.7. The unadjusted yield, shown in the first row of Table 5.7, does not take into account the natural gas used in steam reforming for hydrogen production. It is of interest to know what the yield of fuel products would be if only renewable feedstocks were used. In the base case, hydrogen for the upgrading reactors is generated in a conventional steam reformer using offgas from the upgrading reactors plus natural gas. This hydrogen could also be derived from renewable resources, for example by 1) gasifying biomass, then shifting the syngas to hydrogen or by 2) steam reforming a portion of the fast pyrolysis oil. It is estimated that if the natural gas used to generate hydrogen was replaced by biomass or bio-oil, approximately one third of the biomass feedstock would be needed for hydrogen generation. The yield of fuel products on a 100% renewable basis is shown in the second row of Table 5.7. The third row of Table 5.7 shows the 100% renewable yield on an ethanol equivalent basis (lower heating value (LHV) adjusted). Table 5.7 also summarizes water, power and NG consumption.

**Table 5.7.** Overall Yields and Consumption

	Model
Fuel Product, gal/st dry wood – unadjusted for natural gas usage in the reformer	100
Fuel Product, gal/st dry wood – adjusted to 100% renewable feedstock basis	65
LHV ethanol equivalent Fuel Product, gal/st dry wood, 100% renewable basis	~100
Gallons makeup water/gallons fuel product	3.0
Power, kWh/gallon fuel product	2.5
Natural Gas, scf/gallon fuel product	42

Table 5.8 shows the carbon balance. More than half of the carbon in the combined biomass plus natural gas feed is converted into fuel products.

**Table 5.8.** Carbon Balance

Feeds	Biomass	88%
	Natural Gas	12%
	sum	100%
Fuel Products	Gasoline Pool	23%
	Diesel Pool	32%
	Fuels sum	55%
Waste Products	Pyrolysis Unit Exhaust	23%
	Upgrading Wastewater	0%
	Upgrading Heaters Exhaust	2%
	Reformer Exhaust	20%
	Waste sum	45%

The heat and material balance for the Stand-Alone Design Case is located in Appendix A.

## 6.0 Process Economics

### 6.1 Capital Costs

The cost basis assumes that this is the n<sup>th</sup> plant. Capital costs for the pyrolysis unit, the hydrocracker unit, and the hydrogen plant are from literature sources. The heat and material balance was used to size standard equipment using CHEMCAD<sup>®</sup> sizing routines or by using standard literature sources (Perry et al. 1984, Couper et al. 2005). ASPEN Icarus<sup>™</sup> was used to obtain bare equipment costs for sized equipment. The 2007 annual Chemical Engineering Index was used to escalate capital costs to 2007. Equipment sizing and cost sources are summarized below. Additional details can be found in Appendix B.

#### 6.1.1 Pyrolysis Unit

Existing pyrolysis units process 200 tpd of biomass or less, and capital cost data is limited. This report used data from Ringer et al. 2006, scaled to 2000 tpd. Costs associated with feed handling, pyrolysis reactor, quench, and product recovery were included. Heat recovery and power generation were excluded. The 35% equipment contingency used in Ringer et al. 2006 was retained. As seen in Table 6.1, these costs are within the average of the data shown.

**Table 6.1.** Pyrolysis Unit Literature Capital Cost

Study Date	Original Scale, mtpd	2007 TIC MM\$ at 2000 tpd	Power, kW-h /tonne	Source	Notes
2003	96	68.7	40	(a)	Cost for 5 96-tpd units
2003	490	55.5	156	(b)	Estimated from 40-60 MWth data
2007	200	48.5		(c)	Dynamotive Plant
2006	550	44.5	192	(d)	TIC includes 35% equipment contingency
1990	1001	33.7		(e)	20 fluidized beds @ 100 tpd level
2003	500	39.2	156	(b)	Estimated from 15-140 MWth data
2003	96	35.5		(f)	Cost scaled with 6/10 rule
1990	1001	27.1	167	(e)	1 circulating fluidized-bed pyrolysis unit

(a) Bridgewater et al 2002

(b) Solantausta 2003

(c) Dynamotive 2007

(d) Ringer et al 2006

(e) Beckman et al 1990

(f) Johnson et al 2006

#### 6.1.2 Pyrolysis Oil Hydrotreating and Hydrocracking

Most of the equipment for this section were sized using CHEMCAD<sup>®</sup> and costed using ASPEN Icarus<sup>™</sup> or taken from vendor budgetary quotes. The cost of a small hydrocracker system processing hydrotreated bio-oil has been estimated by UOP (Marker et al. 2005). The large-diameter, high-pressure hydrotreater vessels are likely to be manufactured outside of the United States. A 15% equipment contingency was added to account for uncertainty in the fabrication and hydrocracker unit costs.

### 6.1.3 Hydrogen Generation

Hydrogen generation by steam reforming of natural gas is a well-known, mature process; therefore no equipment contingency was added. The SRI Yearbook (SRI International 2007) and Foster Wheeler (Gulf 2006, Meyer 2004) have published capital and operating data for plants of various capacities.

### 6.1.4 Balance of Plant

Storage capacity and cooling tower capital were estimated with ASPEN Icarus. Wastewater treatment costs are from Beckman et al. 1990. A 15% process contingency was added.

Table 6.2 and Table 6.3 list the stand-alone design case installed equipment capital costs and the factors used to determine the total project investment, respectively. The factors in Table 6.2 are from Peters et al (2003).

**Table 6.2.** Total Project Investment Cost for the Design Case Stand-Alone Plant

	2007 MMUSD	% Contribution
Fast Pyrolysis	92	30%
Hydrotreating	81	27%
Hydrocracking and Separations	29	10%
Hydrogen Generation	86	28%
Utilities, etc.	14	5%
	303*	100
* Summation higher due to rounding		

**Table 6.3.** Total Project Investment Factors

Total Purchased Equipment Cost (TPEC)	100%	
Purchased Equipment Installation	39%	of TPEC
Instrumentation and Controls	26%	of TPEC
Piping	31%	of TPEC
Electrical Systems	10%	of TPEC
Buildings (including services)	29%	of TPEC
Yard Improvements	12%	of TPEC
Total Installed Cost (TIC)	247%	
Indirect Costs		
Engineering	32%	of TPEC
Construction	34%	of TPEC
Legal and Contractors Fees	23%	of TPEC
Project Contingency	37%	of TPEC
Total Indirect	126%	
Total Project Investment	373%	

## 6.2 Operating Costs

Table 6.4 lists the assumptions used to calculate the operating costs. Catalyst costs were escalated with the average Producer Price Index for 2007.

**Table 6.4.** Operating Cost Assumptions

	Value
<b>Raw Materials</b>	
Hybrid Poplar Chips, \$/dry short ton	50.70
Ash Disposal, \$/short ton	18 <sup>(a)</sup>
Hydrogen (refinery transfer), \$/lb	0.56 <sup>(b)</sup>
Hydrotreating Catalyst, \$/lb (2007)	15.5 <sup>(c)</sup>
Hydrocracking Catalyst, \$/lb (2007)	15.5 <sup>(c)</sup>
Hydrogen Plant Catalysts, \$/1000 scf H <sub>2</sub> (2007)	3.6 <sup>(c)</sup>
<b>Utilities</b>	
Natural Gas, \$/1000scf (1000 Btu/scf)	7.68 <sup>(d)</sup>
Electricity, ¢/kwh	6.36 <sup>(d)</sup>
<b>Labor</b>	
Operating labor, \$/hr burdened & 10% shift overlap	37.66 <sup>(c)</sup>
Maintenance and overhead	95% of labor & supervision <sup>(e)</sup>
<b>Materials</b>	
Maintenance	2% of total project investment <sup>(e)</sup>
Local taxes & insurance	2% of total project investment <sup>(e)</sup>
(a) Phillips et al. 2007	
(b) Holmgren et al. 2007	
(c) SRI International 2007	
(d) Energy Information Agency 2007	
(e) Phillips et al. 2007	

## 6.3 Minimum Fuel Selling Price

The minimum fuel product selling price (MFSP) for the gasoline and diesel blendstock was determined using a discounted cash flow rate of return analysis. The methodology is identical to that used in Phillips et al. (2007). The MFSP is the selling price of the fuel that makes the net present value of the process equal to zero with a 10% discounted cash flow rate of return over a 20 year plant life. The stream factor (90%) is lower than that used in Phillips et al. (2007) to account for the shorter catalyst life (1 year versus 5) assumed in this study. While two products are produced, (motor gasoline blendstock and diesel

blendstock), they are combined and referred to as a “fuel product” for simplicity. All MFSP calculations are performed and reported on a combined product basis. Table 6.5 gives the economic parameters used to calculate the MFSP. A sensitivity analysis was conducted to determine the effect of different financial and operating assumptions on the MFSP.

**Table 6.5.** Economic Parameters

	Value
Stream Factor	90%
MACRS Depreciation, yrs	7 <sup>(a)</sup>
Internal Rate of Return, %	10% <sup>(a)</sup>
Plant life, yrs	20 <sup>(a)</sup>
Construction Period	2.5 years <sup>(a)</sup>
1 <sup>st</sup> 6 months' expenditure	8% <sup>(a)</sup>
Next 12 months' expenditure	60% <sup>(a)</sup>
Last 12 months' expenditure	32% <sup>(a)</sup>
Start-up time	6 months <sup>(a)</sup>
Revenues	50% <sup>(a)</sup>
Variable Costs	75% <sup>(a)</sup>
Fixed Costs	100% <sup>(a)</sup>
Working Capital	5% of Total Capital Investment <sup>(a)</sup>
Land	6% of Total Purchased Equipment Cost (taken as 1 <sup>st</sup> year construction expense) <sup>(a)</sup>

(a) Phillips et al. 2007

The variable operating costs were determined from the heat and material balances and checked against published data for the hydrocracker and steam reformer. These and the fixed operating costs are shown in Table 6.6.

**Table 6.6.** Project Economics for the Stand-Alone Design Case Plant

	\$/gal product	Contribution
Feedstock	0.48	23%
Natural Gas	0.32	16%
Catalysts & Chemicals	0.15	7%
Waste Disposal	0.01	0%
Utilities (Cooling Water, Electricity, Steam)	0.17	8%
Fixed Costs (Labor, Operating Supplies, etc.)	0.22	11%
Capital Depreciation	0.20	10%
Average Income Tax	0.13	7%
Average ROI	0.36	18%
MFSP, \$/gal	2.04	
MFSP Ethanol Equivalent Basis, \$/gal	1.34	

The 2007 average refiner prices for gasoline and diesel were \$2.18 and \$2.20 respectively (Energy Information Agency 2007). Thus, at \$2.04/gal fuel product price, there is incentive to pursue motor fuels from biomass.



## 7.0 Economic and Technical Sensitivities

The design case describes a single operating point for a stand-alone processing unit. This section investigates the production cost sensitivities to technical, financial, and market issues. These include plant size, ROI, feedstock costs, reactor conditions and product yields. Because hydrocarbon fuels are the final product, an important sensitivity is the possibility of co-locating the pyrolysis and upgrading facility with an existing refinery.

### 7.1 Co-location with a Refinery

An alternate configuration to the standalone plant described in Section 5 is a facility that is co-located with an existing refinery. Figure 7.1 shows the design case integrated with a refinery. The pyrolysis unit is the same as in the stand-alone case. Co-location eliminates the need for a PSA unit in the hydrotreating section if the upgrading unit off-gas can be sent to refinery hydrogen generation. In return, the upgrading unit receives refinery hydrogen at a lower cost. All final processing of the stable oil to fuels occurs in the refinery.

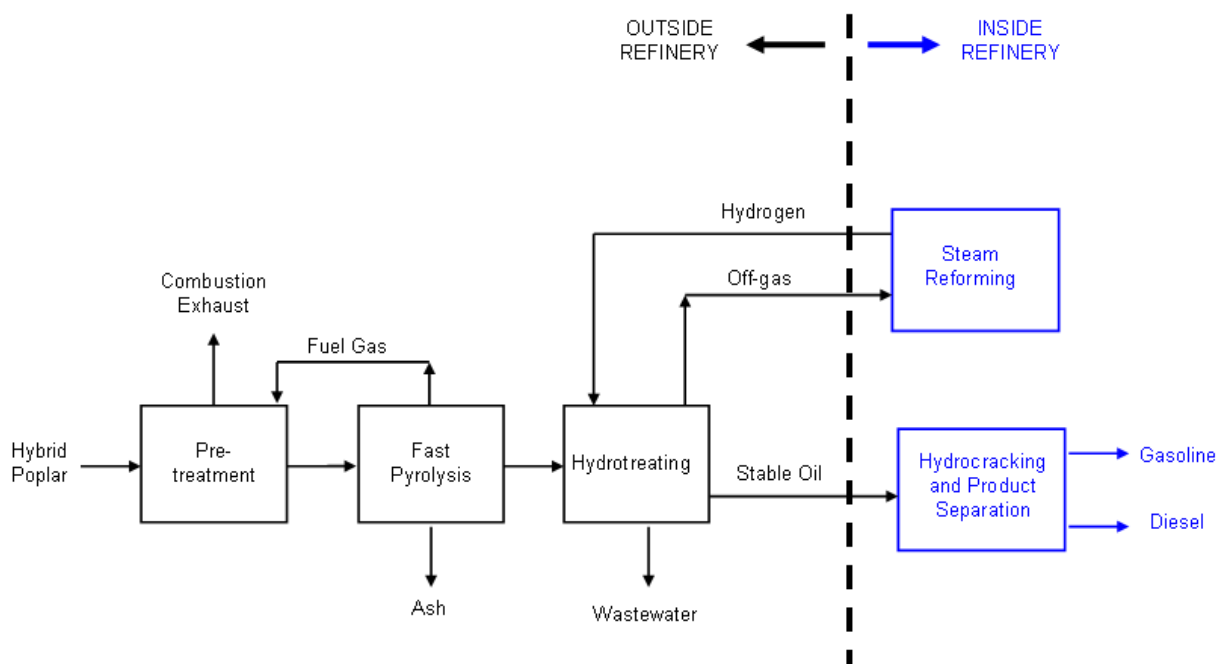

**Figure 7.1.** Block Diagram of Pyrolysis and Upgrading Plant Co-located with a Refinery

VTT and partners (Solantuusta 2006) and UOP (Marker et al 2005, Holmgren et al 2007) are separately pursuing producing bioproducts compatible with existing refinery infrastructure. This will lessen the initial investment; however, direct use of stable oil in a refinery requires complete deoxygenation and a low acid number to prevent corrosion. As an alternative, a finishing deoxygenation unit and/or a separate hydrotreating/hydrocracking operation using dedicated stainless steel equipment may be needed. The finishing hydrotreating unit may result in saturating aromatic compounds, in which case the light naphtha portion may need to be reformed in the refinery into aromatics before blending into gasoline.

Table 7.1 compares the stand-alone and integrated economics. The capital cost calculations assume that the refinery equipment is fully depreciated and only operating costs apply to the refinery side. This greatly reduces the capital investment. A hydrogen transfer price of \$0.56/lb (Holmgren et al 2007) assumes that all operating costs (including feedstock and fuel) to the hydrogen generation unit within the refinery are accounted for in that price. A credit is taken for the fuel gas sent from the upgrading unit to the refinery. The transfer price for the fuel gas to the refinery is determined by adjusting the current price of natural gas for the Btu value of the fuel gas. The product costs are significantly lower than those for the stand-alone plant due to reduced capital investment and the net cost difference between hydrogen and fuel gas.

**Table 7.1.** Comparison of Integrated and Standalone Facilities

	Capital Investment, MM\$	Minimum Selling Price \$/gal fuel product	Minimum Selling Price \$/gal ethanol equivalent
Stand-Alone Plant – Design Case	303	2.04	1.34
Integrated Plant – Design Case	188	1.74	1.14

## 7.2 Financial and Market Sensitivities

The sensitivities to financial assumptions are shown in Figure 7.2. Refinery integration with a \$0.56/lb hydrogen transfer price reduces the base case MFSP by about \$0.30/gal. No refining capital costs were assumed. However, operating costs based on the amount of stable oil processed were included. It is possible that some revamping of refinery equipment will be needed to process the stable oil. The cost of modifying a hydrocracker was estimated by assuming that the incurred costs would not be greater than a small hydrocracker dedicated to stable oil. At a \$0.56/lb hydrogen transfer price, this option reduces the base MFSP by about \$0.13/gal. Finally, the hydrogen transfer price in an integrated facility was varied by \$0.75/lb and \$1.25/lb hydrogen. The MFSP of the integrated facility exceeds that of the base case at hydrogen transfer prices above \$1.00/lb, which is the approximate transfer price for hydrogen if new hydrogen generation facilities must be built.

Sensitivities to project contingency, capital investment, scale and ROI were determined for the stand-alone case. Reducing the project contingency to three percent of the total capital project, (similar to that used in Phillips et al. 2007), reduces the selling price by about \$0.22/gal. The accuracy of the capital estimate is in the range of -10% to +40%, and gives an MFSP range of \$1.79/gal to \$2.22/gal or a difference of -0.22/gal to +\$0.20/gal.

The base plant assumes a 90% stream factor. This may be optimistic with single reactors for fast pyrolysis and upgrading. The equipment spare sensitivity determines the product cost increase if both the pyrolysis unit and upgrading units had 3 reactors at 50% capacity each. This increases the selling price by about \$0.21/gal.

The cost of a single small pyrolysis with an upgrading unit at 500 tpd increases the selling price to almost \$2.68/gal. Four 500 tpd units feeding a single upgrading unit is more cost effective, assuming the feedstock cost is the same for both cases. The cost of transporting biomass feedstock is a limiting factor

in the size of a biomass processing plant. It is possible that small, distributed pyrolysis plants can take advantage of lower feedstock costs and produce an easily transported product that can then be upgraded to fuel in a large, centralized facility. Further analysis is needed to look at the tradeoff between pyrolysis plant size and feedstock cost, and the transportation costs to a centralized upgrading plant.

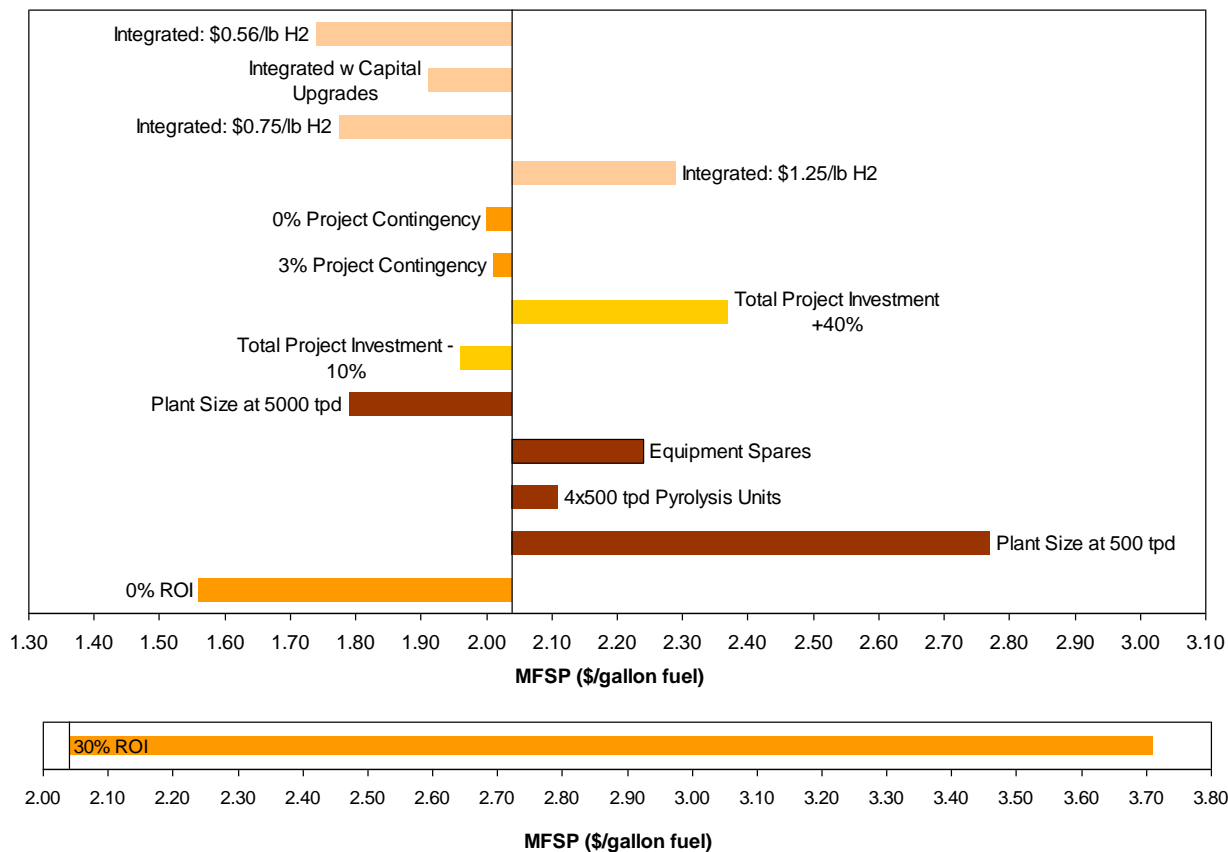

**Figure 7.2.** Financial/Market Sensitivities

The base case assumes a 10% ROI. A 30% return (shown on a separate scale to prevent making the other sensitivities illegible) nearly doubles the baseline estimated selling price. The 0% return represents the plant gate costs.

### 7.3 Research Sensitivities

The research sensitivities are shown in Figure 7.3. Feedstock cost, reactor space velocity, reactor pressure, and catalyst life all impact the minimum selling price for the standalone case. None of these costs alone make the process uneconomic. However, the potential combined effects, such as catalyst life and space velocity, are significant enough to warrant further research. Catalyst costs are important because there is little data on life and the appropriate catalyst composition. As a base case, this study assumes standard hydrotreating and hydrocracking catalysts.

The base case assumes that the two stage hydrotreaters described in Section 5.2 sufficiently deoxygenate the stable oil, and only the heavy tail end requires hydrocracking. If this is not sufficient,

and the entire stable oil stream is sent to the hydrocracker, the size of the hydrocracker increases significantly. Hydrocracking the entire stable oil stream adds \$0.10/gal to price of the fuel.

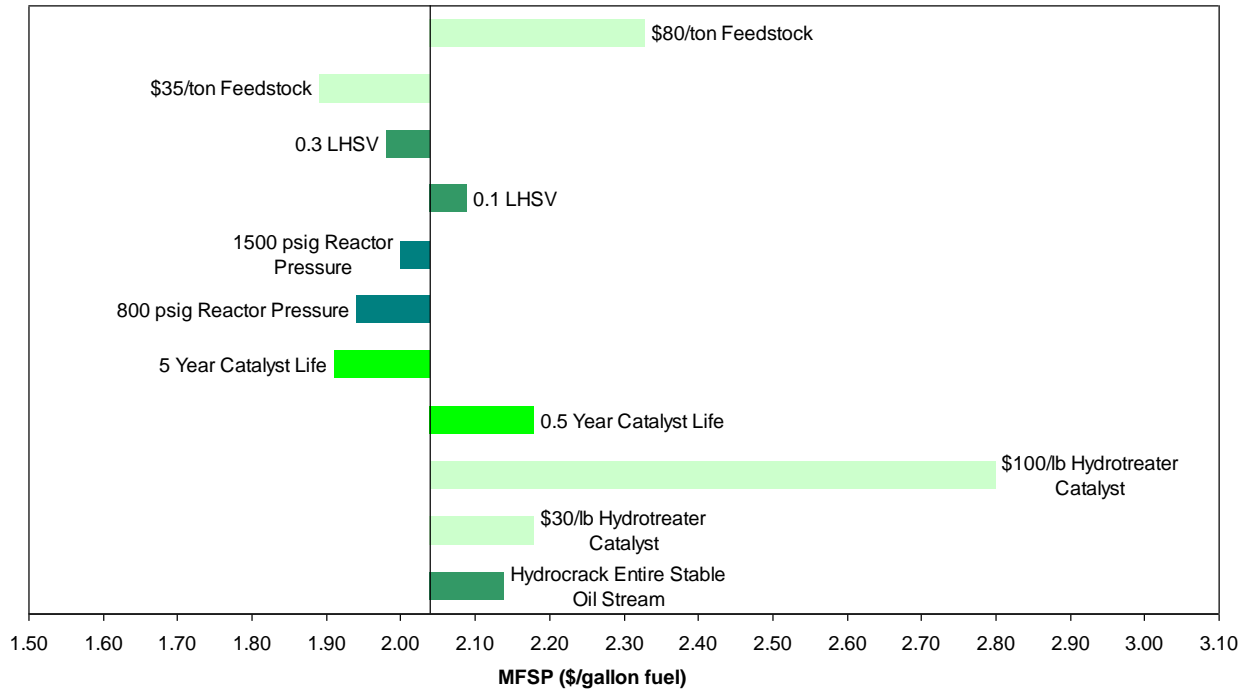

**Figure 7.3.** Research Sensitivities

## 8.0 Conclusions and Recommendations

This analysis suggests that production of hydrocarbon motor fuels from biomass via the pyrolysis route is potentially economically attractive. The cost becomes even more favorable if the facility can be closely associated with an existing petroleum refinery to leverage that infrastructure. Both the stand-alone plant that combines fast pyrolysis with hydrotreating, upgrading and hydrocracking to fuels and the refinery-integrated plant fit with the existing infrastructure in terms of products and processing methods. Developing partnerships with industry suppliers and refiners is important for production development and product acceptance.

The pyrolysis pathway for producing hydrocarbon fuels is economically competitive with either the biological or thermochemical pathways for production of ethanol fuels. On an energy-equivalent basis, as shown in Table 7.1, the costs of either hydrocarbon or alcohol fuels are essentially the same when consistent analysis methodologies and underlying financial assumptions are used.

As indicated previously, other pyrolytic processes exist, and the economics of those processes may be different from the one analyzed here. This analysis suggests that cost-effective processing routes to hydrocarbon fuels exist, but does not attempt to compare this approach with others. If other pyrolytic processing routes have lower costs, the production of hydrocarbon fuels will be even more attractive.

The analysis describes a system with performance projected to be available in 2012. Further research and development is needed to understand the limitations of the process and where improvements can be made. The sensitivity analysis (Figure 7.3) suggests that the biggest impacts of technical improvements are in the area of catalysis as it relates to bio-oil upgrading. Catalyst lifetimes and performance are essential to the process and need additional development and testing. Pyrolytic processing of the biomass is a relatively small percentage of the overall cost, and changes to the pyrolysis process will have little direct impact on the fuel cost. However, research on pyrolytic processing that leads to a better quality bio-oil requiring less upgrading could also potentially reduce product costs.

The analysis (Figure 7.2) also shows the fuel costs are highly sensitive to plant size and ROI. The close coupling of the upgrading steps with a petroleum refinery helps leverage the economies of scale in the fuel production steps. The pyrolysis step to produce bio-oil is less sensitive to scale and can potentially be decoupled from the fuel upgrading step. This analysis uses figures for ROI that are consistent with previous biofuels analyses produced by DOE and allow comparison with other technology options. Industries attempting to build actual facilities may use different assumptions, and the costs for the resulting fuels would change accordingly.

To achieve the potential for producing hydrocarbon fuels from biomass, additional research and development are needed. A summary of needs includes the following:

- Understand the trade-off between the size of the pyrolysis oil plant and feedstock and transportation costs to a centralized upgrading facility.
- Incorporate the reductions in feed preprocessing (grinding and drying) by using a reactor ready feed.
- Understand pyrolysis reactor and upgrading reactor scale-up limitations if any.
- Improve the quality and consistency of bio-oil.

- Determine detailed characterization of upgraded oil and products, for example:
  - boiling point curves and densities
  - compound types (% aromatics, naphthenes, olefins, iso and normal) within the gasoline, diesel and heavy fraction ranges
  - acid number.
- Conduct catalyst life studies for the pyrolysis oil upgrading catalysts.
- Develop better understanding of reactor limitations and opportunities by developing a predictive pyrolysis-oil production model and upgrading the reactor model to replace the stoichiometric models used in this study.
- Determine stable oil and product fuel specifications for oil refinery acceptance.

In addition, there are new initiatives for an advanced pyrolysis process for biomass, the details of which fall outside this base-case study. Incorporation of those new concepts into economic assessments of future cases for biomass pyrolysis should be the next stage of analysis. Advanced pyrolysis processes may include:

- new reactor system engineering involving improved heat transfer mechanisms
- pyrolysis including *in-situ* catalysis
- pyrolysis including *in-situ* chemical processing
- post pyrolysis processing to improve product bio-oil properties
- in-process separation systems to produce bio-oil fractions with useful properties
- post-process separations and subsequent treatment to produce improved products
- higher efficiency integrated systems with improved heat utilization.

## 9.0 References

- Aden A, M Ruth, K Ibsen, J Jechura, K Neeves, J Sheehan, B Wallace, L Montague, A Slayton, and J Lukas. 2002. *Lignocellulosic Biomass to Ethanol Process Design and Economics Utilizing Co-Current Dilute Acid Prehydrolysis and Enzymatic Hydrolysis for Corn Stover*. NREL/TP-510-32438, National Renewable Energy Laboratory, Golden, Colorado. <http://www.nrel.gov/docs/fy02osti/32438.pdf>
- Beckman D, DC Elliott, B Gevert, C Hornell, B Kjellstrom, A Ostman, Y Solantausta, and V Tuhnheim. 1990. *Techno-economic Assessment of Selected Biomass Liquefaction Processes*. Research Report 697, VTT Technical Research Centre of Finland.
- Bridgewater, T. 2007. *Biomass Pyrolysis*. T34:2007:01, International Energy Agency Bioenergy, Rotorua, New Zealand. <http://www.ieabioenergy.com/MediaItem.aspx?id=5416>
- Bridgewater AV, AJ Toft, and JG Brammer. 2002. "A Techno-economic Comparison of Power Production by Biomass Fast Pyrolysis with Gasification and Combustion". *Renewable & Sustainable Energy Reviews* 6:181-248.
- BTG website: <http://www.btgworld.com>. Accessed 1/2009.
- Couper JR, WR Pennery, JR Fair, and SM Walas. 2005. *Chemical Process Equipment Selection and Design*. 2<sup>nd</sup> ed. Elsevier, Amsterdam.
- Diebold JP. 2000. *A Review of the Chemical and Physical Mechanisms of the Storage Stability of Fast Pyrolysis Bio-Oils*. NREL/SR-570-27613, Golden, Colorado. <http://www.nrel.gov/docs/fy00osti/27613.pdf>
- U.S. Department of Energy. 2008. *Biomass Multi-Year Program Plan*. Office of the Biomass Program, Energy Efficiency and Renewable Energy, U.S. Department of Energy, Washington D.C. [http://www1.eere.energy.gov/biomass/pdfs/biomass\\_program\\_mypp.pdf](http://www1.eere.energy.gov/biomass/pdfs/biomass_program_mypp.pdf)
- Dynamotive. 2007. "Dynamotive, The Evolution of Energy." Accessed 2/5/2008 at <http://www.dynamotive.com/en/news/releases/2007/december/071205.html>
- Energy Information Agency. Industrial Electricity and Natural Gas Prices Jan-Nov 2007 average. Retail Gasoline and Diesel Prices Jan-Sept. 2007. Available at <http://www.eia.doe.gov/>
- Ensyn website 2009. <http://www.ensyn.com/about.htm>
- Elliott, DC. 2007. "Historical Developments in Hydroprocessing Bio-oil." *Energy & Fuels* 21:1792-1815.
- Freel B and R Graham. 1995. "Method and Apparatus for a Circulating Bed Transport Fast Pyrolysis Reactor System." US Patent 5,792,340. Ensyn Technologies Inc.
- Gulf Publishing Co. 2006. *Hydrocarbon Processing; Refining Processes 2006*. Gulf Publishing Co., Houston, Texas.
- Holmgren J, C Gosling, R Mariangeli, T Marker, G Rafaci, and C Perego. 2007. "New Developments in Renewable Fuels Offer More Choices." *Hydrocarbon Processing* 86:59-72.

Johnson WL, GH Yavari, and D St A G Radelin. 2006. "Apparatus for Separating Fouling Contaminants from Non-Condensable Gases at the End of a Pyrolysis/Thermolysis of Biomass Process." US Patent 7,004,999 B2. Dynamotive Energy Systems.

Marker T, J Petri, T Kalnes, M McCall, D Mackowiak, B Jerosky, B Regan, L Nemeth, M Krawczyk, S Czernik, D Elliot, and D Shonnard. 2005. "Opportunities for Biorenewables in Oil Refineries." UOP, Des Plaines, Illinois. [http://www.osti.gov/energycitations/product.biblio.jsp?osti\\_id=861458](http://www.osti.gov/energycitations/product.biblio.jsp?osti_id=861458)

Meyers RA. 2004. *Handbook of Petroleum Refining Processes*. 3<sup>rd</sup> ed. McGraw-Hill, New York.

Mohan D, C Pittman, and P Steele. 2006. "Pyrolysis of Wood/Biomass for Bio-oil: A Critical Review." *Energy & Fuels* 20:848-889.

Oasmaa A and E Kuoppala. 2003. "Fast Pyrolysis of Forestry Residue. 3. Stability of Liquid Fuel." *Energy & Fuels* 17:1075-1084.

Parkash, S. 2003. "Hydrocracking Processes." Chapter 3 in *Refining Processes Handbook*. Gulf Professional Publishing/Elsevier, Boston/Amsterdam.

Perry RH, DW Green, and JO Maloney. 1984. *Perry's Chemical Engineers' Handbook*. 6<sup>th</sup> ed. McGraw-Hill, New York.

Peters MS, KD Timmerhaus, and RE West. 2003. *Plant Design and Economics for Chemical Engineers*. 5<sup>th</sup> ed, McGraw-Hill, New York.

Phillips S, A Aden, and J Jechura, D Dayton, and T Eggman 2007. *Thermochemical Ethanol via Indirect Gasification and Mixed Alcohol Synthesis of Lignocellulosic Biomass*. NREL/TP-510-41168. National Renewable Energy Laboratory, Golden, Colorado. <http://www.nrel.gov/docs/fy07osti/41168.pdf>

Phyllis Database for Biomass and Waste. "Hybrid Poplar." Version 4.13. Energy Research Center of the Netherlands. <http://www.ecn.nl/phyllis>

Ringer M, V Putsche, and J Scahill. 2006. *Large-Scale Pyrolysis Oil Production: A Technology Assessment and Economic Analysis*. NREL/TP-510-37779. National Renewable Energy Laboratory, Golden, Colorado.

Solantausta Y. 2003. *Techno-Economic Assessment, the Finnish Case Study*. COMBIO Project NNE5-CT-00604, VTT Technical Research Centre of Finland, <http://www.combio-project.com/economics.htm>

Solantuasta Y. 2006. "Co-Processing of Upgraded Bio-Liquids in Standard Refinery Units – BIOCUP." European Conference on Biorefinery Research Proceedings. [http://ec.europa.eu/research/energy/gp/gp\\_events/biorefinery/article\\_3764\\_en.htm](http://ec.europa.eu/research/energy/gp/gp_events/biorefinery/article_3764_en.htm)

Spath P, A Aden, T Eggeman, M Ringer, B Wallace, and J Jechura. 2005. *Biomass to Hydrogen Production Detailed Design and Economics Utilizing the Battelle Columbus Laboratory Indirectly-Heated Gasifier*. NREL/TP-510-37408, National Renewable Energy Laboratory, Golden, Colorado. <http://www.nrel.gov/docs/fy05osti/37408.pdf>

SRI International. 2007. "Hydrogen Production from Natural Gas." *PEP Yearbook International*, Vol 1E, SRI International, Menlo Park, California.

White House Office of Communications. 2007. *Twenty in Ten: Strengthening America's Energy Security*. White House Office of Communications, Washington D.C. Available at <http://www.energy.gov/media/20in10FactSheet.pdf>

## **Appendix A**

### **Design Case – Stand-Alone Heat and Material Balance**

A.1

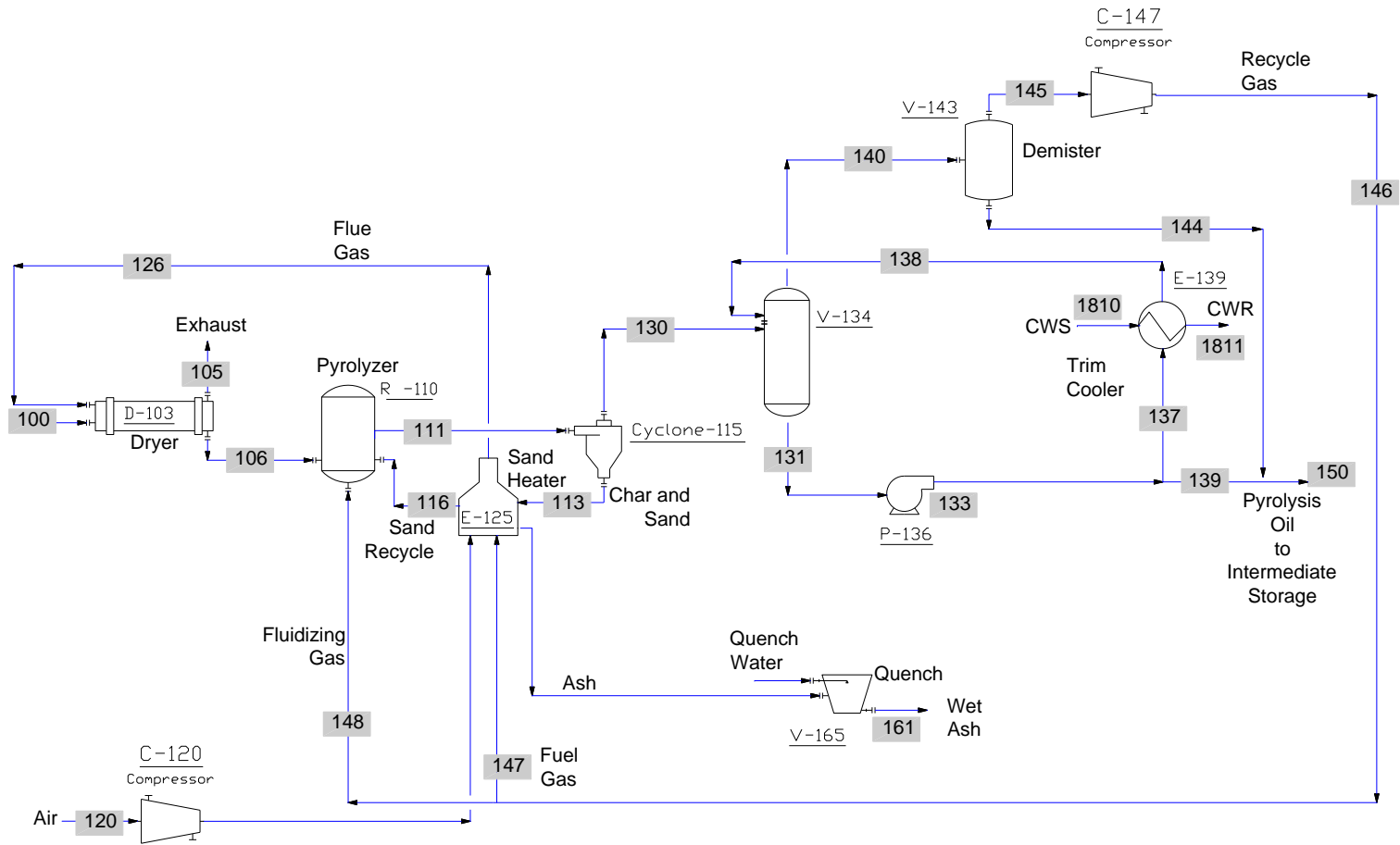

Figure A.1. Flow Diagram for Pyrolysis Unit

**Table A.1. Pyrolysis Unit Heat and Material Balance**

Stream No.	100	105	106	111	113	116	120	126	130	131	133
Temp C	20	176.587	66	499.421	499.421	592	15.5555	1211.84	499.421	43.7381	43.746
Pres psig	3	3	3	1	1	1	0.3041	3	1	1	10
Enth MMBtu/h	-1743	-1324.9	-575.9	-6192.3	-5449.1	-5322.2	-1.4752	-157.77	-743.17	-96574	-96573
Vapor mass fraction	0	1	0	1	1	0	1	1	1	0	4.17E-05
Total lb/h	367436	560708	197546	3135535	2779270	2755767	350000	390817	356265	2.7E+07	2.7E+07
Flowrates in lb/h											
Oxygen	0	24433.8	0	3873.85	3873.85	0	81520.1	24435	0	0	0
Nitrogen	0	269595	0	10673.8	0	0	268480	269595	10673.8	80.5111	80.496
Water	183718	180076	13828.2	32280.7	0	0	0	10186	32280.7	4480534	4480506
Hybrid Poplar	183718	0	183718	0.0041	0.0041	0	0	0	0	0	0
Hydrogen	0	2.0727	0	1403.29	963.918	0	0	2.0729	439.369	1.3593	1.359
Carbon	0	0	0	15065.9	15065.9	0	0	0	0	0	0
Carbon Monoxide	0	513.829	0	175437	0	0	0	513.888	175437	1272.26	1272.03
Carbon Dioxide	0	86088.1	0	9738.7	0	0	0	86085.5	9738.7	2331.92	2331.05
Methane	0	0.0002	0	876.195	0	0	0	0.0002	876.195	27.2094	27.2046
Ethylene	0	0.0004	0	3488.06	0	0	0	0.0004	3488.06	475.291	475.223
Ethane	0	0	0	0	0	0	0	0	0	0	0
Propylene	0	0.0006	0	3629.54	0	0	0	0.0006	3629.54	2174.05	2173.91
Propane	0	0	0	0	0	0	0	0	0	0	0
I-Butane	0	0	0	0	0	0	0	0	0	0	0
Ammonia	0	0.0003	0	285.508	0	0	0	0.0003	285.508	468.22	468.193
Pyro-lignin	0	0	0	64485	0	0	0	0	64485	1.2E+07	1.2E+07
Cellobiose	0	0	0	22689.1	0	0	0	0	22689.1	4500798	4501477
Levogluconan	0	0	0	5970.83	0	0	0	0	5970.83	1087896	1087571
Furfural	0	0	0	11941.7	0	0	0	0	11941.7	2078346	2078007
HydroxyAcetone	0	0	0	5970.83	0	0	0	0	5970.83	1098279	1098360
Acetic Acid	0	0	0	8359.16	0	0	0	0	8359.16	1192790	1192921
Formaldehyde	0	0	0	0	0	0	0	0	0	0	0
2-5-Xylenol	0	0	0	0	0	0	0	0	0	0	0
N-Heptane	0	0	0	0	0	0	0	0	0	0	0
1-ts-35-3C1CycC6	0	0	0	0	0	0	0	0	0	0	0
3-3-5-TriMth-C7	0	0	0	0	0	0	0	0	0	0	0
N-PropylCyc-C6	0	0	0	0	0	0	0	0	0	0	0
1-2-3-Mesitylene	0	0	0	0	0	0	0	0	0	0	0
N-ButylCycHexane	0	0	0	0	0	0	0	0	0	0	0
1-2-DiC1-3C2-Bz	0	0	0	0	0	0	0	0	0	0	0
Cis-Decalin	0	0	0	0	0	0	0	0	0	0	0
Dimethyl-C11	0	0	0	0	0	0	0	0	0	0	0
1-2-4-triethylbe	0	0	0	0	0	0	0	0	0	0	0
1-1-Bicyclohexyl	0	0	0	0	0	0	0	0	0	0	0
Diphenyl	0	0	0	0	0	0	0	0	0	0	0
diamantane	0	0	0	0	0	0	0	0	0	0	0
Phenanthrene	0	0	0	0	0	0	0	0	0	0	0
N-C15-CycloC5	0	0	0	0	0	0	0	0	0	0	0
Hexatriacontane	0	0	0	0	0	0	0	0	0	0	0
Ca	0	0	0	3496.15	3496.15	0	0	0	0	0	0
Sulphur	0	0	0	36.0271	36.0271	0	0	0	0	0	0
Calcium Chloride	0	0	0	67.057	67.057	0	0	0	0	0	0
Sand	0	0	0	2755767	2755767	2755767	0	0	0	0	0

Table A.1. (contd)

Stream No.	137	138	139	140	144	145	146	147	148	150	161
Temp C	43.746	37.7778	43.746	43.7381	43.7381	43.7381	91.8145	91.8145	91.8145	43.7199	105.294
Pres psig	10	5	10	1	1	1	8	8	8	1	3
Enth MMBtu/h	-96072	-96222	-501.34	-391.99	-69.9	-332.32	-327.7	-33.491	-294.2	-571.24	-37.313
Vapor mass fraction	4.17E-05	4.70E-05	4.17E-05	1	0	1	1	1	1	5.38E-05	0.50092
Total lb/h	3E+07	2.7E+07	139274	216984	12363	204621	204621	20912.8	183708	151637	9599.24
Flowrates in lb/h											
Oxygen	0	0	0	0	0	0	0	0	0	0	0
Nitrogen	80.078	80.0782	0.4179	10673.4	0	10673.4	10673.4	1090.85	9582.52	0.4179	0
Water	4E+06	4457246	23259.8	8992.01	8902.09	89.9201	89.9201	9.1901	80.73	32161.8	6000
Hybrid Poplar	0	0	0	0	0	0	0	0	0	0	0
Hydrogen	1.352	1.352	0.0071	439.362	0	439.362	439.362	44.904	394.458	0.0071	0
Carbon	0	0	0	0	0	0	0	0	0	0	0.0002
Carbon Monoxide	1265.4	1265.43	6.6035	175430	0	175430	175430	17929.4	157500	6.6035	0
Carbon Dioxide	2319	2318.95	12.1013	9725.74	0	9725.74	9725.74	993.998	8731.74	12.1012	0
Methane	27.063	27.0633	0.1412	876.049	0	876.049	876.049	89.5347	786.514	0.1412	0
Ethylene	472.76	472.756	2.467	3485.52	0	3485.52	3485.52	356.23	3129.29	2.467	0
Ethane	0	0	0	0	0	0	0	0	0	0	0
Propylene	2162.6	2162.62	11.2855	3618.11	0	3618.11	3618.11	369.781	3248.33	11.2855	0
Propane	0	0	0	0	0	0	0	0	0	0	0
I-Butane	0	0	0	0	0	0	0	0	0	0	0
Ammonia	465.76	465.763	2.4305	283.051	0	283.051	283.051	28.9286	254.123	2.4305	0
Pyro-lignin	1E+07	1.2E+07	64281.4	0.044	0.044	0	0	0	0	64281.4	0
Cellobiose	4E+06	4478109	23368.6	0.0129	0.0129	0	0	0	0	23368.7	0
Levogluconan	1E+06	1081925	5645.94	0.0011	0.0011	0	0	0	0	5645.94	0
Furfural	2E+06	2067219	10787.6	814.207	814.207	0	0	0	0	11601.8	0
HydroxyAcetone	1E+06	1092658	5701.95	349.864	349.864	0	0	0	0	6051.81	0
Acetic Acid	1E+06	1186728	6192.84	2296.82	2296.82	0	0	0	0	8489.66	0
Formaldehyde	0	0	0	0	0	0	0	0	0	0	0
2-5-Xylenol	0	0	0	0	0	0	0	0	0	0	0
N-Heptane	0	0	0	0	0	0	0	0	0	0	0
1-ts-35-3C1CycC6	0	0	0	0	0	0	0	0	0	0	0
3-3-5-TriMth-C7	0	0	0	0	0	0	0	0	0	0	0
N-PropylCyc-C6	0	0	0	0	0	0	0	0	0	0	0
1-2-3-Mesitylene	0	0	0	0	0	0	0	0	0	0	0
N-ButylCycHexane	0	0	0	0	0	0	0	0	0	0	0
1-2-DiC1-3C2-Bz	0	0	0	0	0	0	0	0	0	0	0
Cis-Decalin	0	0	0	0	0	0	0	0	0	0	0
Dimethyl-C11	0	0	0	0	0	0	0	0	0	0	0
1-2-4-triethylbe	0	0	0	0	0	0	0	0	0	0	0
1-1-Bicyclohexyl	0	0	0	0	0	0	0	0	0	0	0
Diphenyl	0	0	0	0	0	0	0	0	0	0	0
diamantane	0	0	0	0	0	0	0	0	0	0	0
Phenanthrene	0	0	0	0	0	0	0	0	0	0	0
N-C15-CycloC5	0	0	0	0	0	0	0	0	0	0	0
Hexatriacontane	0	0	0	0	0	0	0	0	0	0	0
Ca	0	0	0	0	0	0	0	0	0	0	3496.16
Sulphur	0	0	0	0	0	0	0	0	0	0	36.0271
Calcium Chloride	0	0	0	0	0	0	0	0	0	0	67.057
Sand	0	0	0	0	0	0	0	0	0	0	0

**Table A.1. (contd)**

Stream No.	1810	1811
Temp C	32.2222	40.5555
Pres psig	50	45
Enth MMBtu/h	-68430	-68279
Vapor mass fraction	0	0
Total lb/h	10044315	10044310
Flowrates in lb/h		
Oxygen	0	0
Nitrogen	0	0
Water	10044315	10044310
Hybrid Poplar	0	0
Hydrogen	0	0
Carbon	0	0
Carbon Monoxide	0	0
Carbon Dioxide	0	0
Methane	0	0
Ethylene	0	0
Ethane	0	0
Propylene	0	0
Propane	0	0
I-Butane	0	0
Ammonia	0	0
Pyro-lignin	0	0
Cellulose	0	0
Levoglucosan	0	0
Furfural	0	0
HydroxyAcetone	0	0
Acetic Acid	0	0
Formaldehyde	0	0
2-5-Xylenol	0	0
N-Heptane	0	0
1-ts-35-3C1CycC6	0	0
3-3-5-TriMth-C7	0	0
N-PropylCyc-C6	0	0
1-2-3-Mesitylene	0	0
N-ButylCycHexane	0	0
1-2-DiC1-3C2-Bz	0	0
Cis-Decalin	0	0
Dimethyl-C11	0	0
1-2-4-triethylbe	0	0
1-1-Bicyclohexyl	0	0
Diphenyl	0	0
diamantane	0	0
Phenanthrene	0	0
N-C15-CycloC5	0	0
Hexatriacontane	0	0
Ca	0	0
Sulphur	0	0
Calcium Chloride	0	0
Sand	0	0

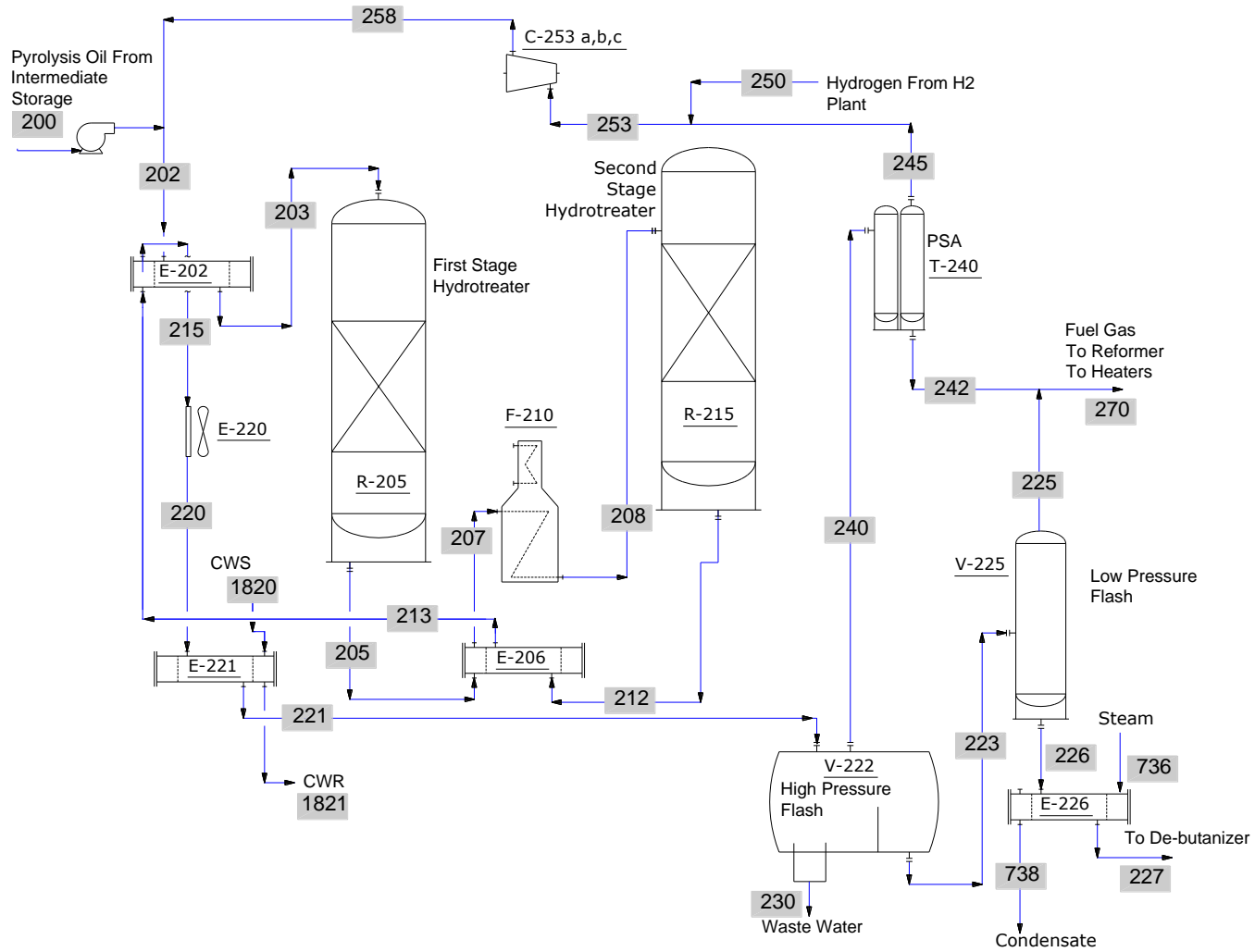

Figure A.2. Flow Diagram for Pyrolysis Oil Stabilization

**Table A.2. Pyrolysis Oil Hydrotreating Heat and Material Balance**

Stream No.	200	202	203	205	207	208	212	213	215	220	221
Temp F	110.6798	174.8342	430	465.5045	470	700	484.8971	481.4931	319.3935	150	110
Pres psig	1	2500	2495	2495	2490	2475	2475	2470	710.3041	705.3041	700.3041
Enth MMBtu/h	-579.38	-572.13	-533.75	-533.75	-532.53	-493.17	-493.17	-494.39	-532.77	-560.91	-566.01
Vapor mass fraction	0	0.062243	0.15953	0.24881	0.25969	0.52647	0.6898	0.67505	0.22969	0.12881	0.12332
Total lb/h	151607.6	161371	161371	161371	161371	161371	161371	161374.8	161374.8	161374.8	161374.8
Flowrates in lb/h											
Water	32161.65	32161.64	32161.64	44375.22	44375.22	44375.22	71936	71936	71936	71936	71936
Hydrogen	0	9763.431	9763.431	8474.411	8474.411	8474.411	3839.811	3843.556	3843.557	3843.557	3843.557
Carbon Dioxide	0	0	0	1000	1000	1000	9000.002	9000.002	9000.003	9000.003	9000.004
Methane	0	0	0	50	50	50	3350	3350	3350	3350	3350
Ethane	0	0	0	6.9	6.9	6.9	2006.899	2006.9	2006.9	2006.9	2006.9
Propane	0	0	0	5.1	5.1	5.1	1705.1	1705.101	1705.101	1705.101	1705.101
I-Butane	0	0	0	4.4	4.4	4.4	1504.4	1504.4	1504.4	1504.4	1504.4
Pyro-lignin	64305.6	64305.58	64305.58	54819.78	54819.78	54819.79	0	0	0	0	0
Cellobiose	23313.63	23313.62	23313.62	13988.17	13988.17	13988.17	0.0037	0.0051	0.0051	0.0051	0.0051
Levogluconan	5674.065	5674.063	5674.063	2724.021	2724.021	2724.021	0.001	0.0014	0.0014	0.0014	0.0014
Furfural	11633.4	11633.4	11633.4	0	0	0	0	0	0	0	0
HydroxyAcetone	6044.922	6044.922	6044.922	4835.938	4835.938	4835.938	0	0	0	0	0
Acetic Acid	8474.371	8474.367	8474.367	5084.619	5084.619	5084.619	0	0	0	0	0
2-5-Xylenol	0	0	0	26002.45	26002.45	26002.45	8000.004	8000.002	8000.001	8000.001	8000.001
N-Heptane	0	0	0	0	0	0	3275.653	3275.653	3275.654	3275.654	3275.655
1-ts-35-3C1CycC6	0	0	0	0	0	0	4892.768	4892.769	4892.768	4892.768	4892.769
3-3-5-TriMth-C7	0	0	0	0	0	0	1994.707	1994.707	1994.707	1994.707	1994.707
N-PropylCyc-C6	0	0	0	0	0	0	4892.767	4892.769	4892.769	4892.769	4892.77
1-2-3-Mesitylene	0	0	0	0	0	0	642.0663	642.0664	642.0664	642.0664	642.0665
N-ButylCycHexane	0	0	0	0	0	0	234.2028	234.2029	234.2029	234.2029	234.2029
1-2-DiC1-3C2-Bz	0	0	0	0	0	0	1593.217	1593.217	1593.217	1593.217	1593.217
Cis-Decalin	0	0	0	0	0	0	3186.433	3186.433	3186.433	3186.433	3186.433
Dimethyl-C11	0	0	0	0	0	0	8635.319	8635.321	8635.321	8635.321	8635.322
1-2-4-triethylbe	0	0	0	0	0	0	3186.432	3186.434	3186.434	3186.434	3186.433
1-1-Bicyclohexyl	0	0	0	0	0	0	238.9825	238.9825	238.9825	238.9825	238.9825
Diphenyl	0	0	0	0	0	0	4383.289	4383.289	4383.289	4383.289	4383.289
diamantane	0	0	0	0	0	0	8635.319	8635.321	8635.321	8635.321	8635.322
Phenanthrene	0	0	0	0	0	0	6087.9	6087.901	6087.901	6087.901	6087.902
N-C15-CycloC5	0	0	0	0	0	0	291.442	291.4421	291.442	291.442	291.442
Hexatriacontane	0	0	0	0	0	0	0	0	0	0	0
Chrysene	0	0	0	0	0	0	6120.283	6120.284	6120.283	6120.283	6120.283
Cyclopentane	0	0	0	0	0	0	0	0	0	0	0
N-Pentadecane	0	0	0	0	0	0	0	0	0	0	0
N-Octadecane	0	0	0	0	0	0	0	0	0	0	0
Tetralin	0	0	0	0	0	0	0	0	0	0	0
Ethylbenzene	0	0	0	0	0	0	0	0	0	0	0
Benzene	0	0	0	0	0	0	0	0	0	0	0
N-Butane	0	0	0	0	0	0	0	0	0	0	0
Toluene	0	0	0	0	0	0	0	0	0	0	0
1-3-5-Mesitylene	0	0	0	0	0	0	0	0	0	0	0
P-Xylene	0	0	0	0	0	0	1738.065	1738.064	1738.064	1738.064	1738.065
N-Propylbenzene	0	0	0	0	0	0	0.0131	0.0102	0.0102	0.0102	0.0102

Table A.2. (contd)

Stream No.	223	225	226	227	230	240	242	245	250	253	258
Temp F	100	99.9329	99.9329	200	100	100	44.3597	100	77	84.6947	303.1303
Pres psig	700.3041	35.3041	35.3041	35.3041	700.3041	700.3041	35	300	300	300	2500
Enth MMBtu/h	-33.374	-0.07606	-33.298	-30.008	-487.88	-46.01	-45.02	-0.20059	-0.90996	-1.1106	6.2841
Vapor mass fraction	0	1	0	0.000449	0	1	0.99656	1	1	1	1
Total lb/h	69520.25	25.2322	69495.02	69495.01	72156.03	19698.48	16435.05	3263.436	6500	9763.431	9763.431
Flowrates in lb/h											
Water	242.2865	0.2879	241.9986	241.9986	71621.36	72.3108	72.3111	0	0	0	0
Hydrogen	0.4663	0.455	0.0113	0.0113	3.7543	3839.336	575.9001	3263.436	6500	9763.431	9763.431
Carbon Dioxide	31.1286	17.3243	13.8043	13.8043	250.624	8718.251	8718.251	0	0	0	0
Methane	0.6464	0.6206	0.0258	0.0258	5.2046	3344.148	3344.149	0	0	0	0
Ethane	0.5571	0.5241	0.0331	0.0331	0.0423	2006.3	2006.3	0	0	0	0
Propane	730.0195	3.4583	726.5612	726.5612	17.2753	957.8062	957.8062	0	0	0	0
I-Butane	889.0693	2.1131	886.9562	886.9562	6.5343	608.7963	608.7963	0	0	0	0
Pyro-lignin	0	0	0	0	0	0	0	0	0	0	0
Cellobiose	0	0	0	0	0.0051	0	0	0	0	0	0
Levogluconan	0	0	0	0	0.0014	0	0	0	0	0	0
Furfural	0	0	0	0	0	0	0	0	0	0	0
HydroxyAcetone	0	0	0	0	0	0	0	0	0	0	0
Acetic Acid	0	0	0	0	0	0	0	0	0	0	0
2-5-Xylenol	7748.411	0.0064	7748.406	7748.406	249.3144	2.2761	2.2761	0	0	0	0
N-Heptane	3193.759	0.2507	3193.508	3193.508	0.7128	81.1817	81.1817	0	0	0	0
1-ts-35-3C1CycC6	4857.789	0.0991	4857.69	4857.689	0.1593	34.8195	34.8196	0	0	0	0
3-3-5-TriMth-C7	1987.447	0.0195	1987.427	1987.427	0.015	7.2457	7.2457	0	0	0	0
N-PropylCyc-C6	4878.879	0.0392	4878.839	4878.839	0.1611	13.7284	13.7284	0	0	0	0
1-2-3-Mesitylene	641.6517	0.001	641.6508	641.6508	0.0785	0.3363	0.3363	0	0	0	0
N-ButylCycHexane	233.9581	0.0007	233.9575	233.9575	0.0024	0.2423	0.2423	0	0	0	0
1-2-DiC1-3C2-Bz	1592.735	0.0012	1592.733	1592.733	0.0573	0.4248	0.4248	0	0	0	0
Cis-Decalin	3184.489	0.0052	3184.483	3184.483	0.0499	1.8948	1.8948	0	0	0	0
Dimethyl-C11	8633.4	0.0045	8633.395	8633.395	0.0018	1.9188	1.9189	0	0	0	0
1-2-4-triethylbe	3186.106	0.0008	3186.105	3186.105	0.0099	0.3178	0.3178	0	0	0	0
1-1-Bicyclohexyl	238.9565	0.0001	238.9565	238.9565	0.0004	0.0256	0.0256	0	0	0	0
Diphenyl	4383.134	0.0003	4383.133	4383.133	0.0454	0.1092	0.1092	0	0	0	0
diamantane	8633.234	0.0054	8633.229	8633.229	0.0045	2.0826	2.0826	0	0	0	0
Phenanthrene	6087.885	0	6087.884	6087.884	0.0107	0.0052	0.0052	0	0	0	0
N-C15-CycloC5	291.442	0	291.442	291.442	0	0.0001	0.0001	0	0	0	0
Hexatriacontane	0	0	0	0	0	0	0	0	0	0	0
Chrysene	6120.283	0	6120.283	6120.283	0.0003	0	0	0	0	0	0
Cyclopentane	0	0	0	0	0	0	0	0	0	0	0
N-Pentadecane	0	0	0	0	0	0	0	0	0	0	0
N-Octadecane	0	0	0	0	0	0	0	0	0	0	0
Tetralin	0	0	0	0	0	0	0	0	0	0	0
Ethylbenzene	0	0	0	0	0	0	0	0	0	0	0
Benzene	0	0	0	0	0	0	0	0	0	0	0
N-Butane	0	0	0	0	0	0	0	0	0	0	0
Toluene	0	0	0	0	0	0	0	0	0	0	0
1-3-5-Mesitylene	0	0	0	0	0	0	0	0	0	0	0
P-Xylene	1732.51	0.015	1732.494	1732.494	0.6275	4.927	4.927	0	0	0	0
N-Propylbenzene	0.0102	0	0.0102	0.0102	0	0	0	0	0	0	0

**Table A.2. (contd)**

Stream No.	270	736	738	1820	1821
Temp F	44.4289	700.0002	496.55	90	105
Pres psig	35	645	645	60	55
Enth MMBtu/h	-45.096	-22.468	-25.758	-2320.7	-2315.6
Vapor mass fraction	0.99656	1	1.00E-06	0	0
Total lb/h	16460.28	4037.127	4037.127	341022.1	341022.1
Flowrates in lb/h					
Water	72.5986	4037.127	4037.127	341022.1	341022.1
Hydrogen	576.3552	0	0	0	0
Carbon Dioxide	8735.575	0	0	0	0
Methane	3344.769	0	0	0	0
Ethane	2006.824	0	0	0	0
Propane	961.2645	0	0	0	0
I-Butane	610.9094	0	0	0	0
Pyro-lignin	0	0	0	0	0
Cellobiose	0	0	0	0	0
Levogluconan	0	0	0	0	0
Furfural	0	0	0	0	0
HydroxyAcetone	0	0	0	0	0
Acetic Acid	0	0	0	0	0
2-5-Xylenol	2.2824	0	0	0	0
N-Heptane	81.4324	0	0	0	0
1-ts-35-3C1CycC6	34.9186	0	0	0	0
3-3-5-TriMth-C7	7.2652	0	0	0	0
N-PropylCyc-C6	13.7676	0	0	0	0
1-2-3-Mesitylene	0.3373	0	0	0	0
N-ButylCycHexane	0.243	0	0	0	0
1-2-DiC1-3C2-Bz	0.426	0	0	0	0
Cis-Decalin	1.9	0	0	0	0
Dimethyl-C11	1.9233	0	0	0	0
1-2-4-triethylbe	0.3186	0	0	0	0
1-1-Bicyclohexyl	0.0257	0	0	0	0
Diphenyl	0.1094	0	0	0	0
diamantane	2.088	0	0	0	0
Phenanthrene	0.0052	0	0	0	0
N-C15-CycloC5	0.0001	0	0	0	0
Hexatriacontane	0	0	0	0	0
Chrysene	0	0	0	0	0
Cyclopentane	0	0	0	0	0
N-Pentadecane	0	0	0	0	0
N-Octadecane	0	0	0	0	0
Tetralin	0	0	0	0	0
Ethylbenzene	0	0	0	0	0
Benzene	0	0	0	0	0
N-Butane	0	0	0	0	0
Toluene	0	0	0	0	0
1-3-5-Mesitylene	0	0	0	0	0
P-Xylene	4.942	0	0	0	0
N-Propylbenzene	0	0	0	0	0



**Table A.3. Hydrocracking and Product Separation Heat and Material Balance**

Stream No.	227	302	304	305	306	307	308	309	310	500	508
Temp F	200	203.3611	457.477	308.4405	427.7641	470	734.4869	398.6693	398.8038	744.7188	366
Pres psig	35.3041	35.3041	35.3041	5	5	2	1	1	15	1300	1295
Enth MMBtu/h	-30.008	-4.1857	-15.689	-12.8	-5.6145	-1.3824	5.6133	-10.415	-10.413	5.6658	5.651
Vapor mass fraction	0.000449	1	0	0	0	0.52048	0	0	0	0	0.20116
Total lb/h	69495.01	3466.51	66028.52	19360.17	46668.37	46668.38	8800.003	37868.36	37868.37	8800.005	11010
Flowrates in lb/h											
Water	241.9986	241.9984	0	0	0	0	0	0	0	0	0
Hybrid Poplar Ch	0	0	0	0	0	0	0	0	0	0	0
Hydrogen	0.0113	0.0113	0	0	0	0	0	0	0	0	2129.363
Carbon Dioxide	13.8043	13.8043	0	0	0	0	0	0	0	0	0
Methane	0.0258	0.0258	0	0	0	0	0	0	0	0	0
Ethane	0.0331	0.0331	0	0	0	0	0	0	0	0	0
Propane	726.5612	726.5609	0	0	0	0	0	0	0	0	0
I-Butane	886.9562	886.956	0	0	0	0	0	0	0	0	0
2-5-Xylenol	7748.406	0.0001	7748.407	3162.434	4585.977	4585.977	0.0083	4585.968	4585.968	0.0083	0.0083
N-Heptane	3193.508	1596.752	1596.765	1596.766	0	0	0	0	0	0	0
1-ts-35-3C1CycC6	4857.689	0.0486	4857.643	4541.519	316.1233	316.1233	0.0016	316.1216	316.1216	0.0016	0.0016
3-3-5-TriMth-C7	1987.427	0.0002	1987.428	1856.982	130.4458	130.4458	0.0003	130.4456	130.4456	0.0003	0.0003
N-PropylCyc-C6	4878.839	0.0006	4878.839	3903.073	975.7652	975.7652	0.0087	975.7564	975.7565	0.0087	0.0087
1-2-3-Mesitylene	641.6508	0	641.6508	128.3304	513.3206	513.3206	0.0191	513.3015	513.3015	0.0191	0.0191
N-ButylCycHexane	233.9575	0	233.9575	125.987	107.9707	107.9707	0.0016	107.9691	107.9691	0.0016	0.0016
1-2-DiC1-3C2-Bz	1592.733	0	1592.733	135.2346	1457.499	1457.499	0.0871	1457.412	1457.412	0.0871	0.0871
Cis-Decalin	3184.483	0	3184.484	1024.104	2160.379	2160.379	0.0983	2160.281	2160.281	0.0983	0.0984
Dimethyl-C11	8633.395	0	8633.397	1406.676	7226.72	7226.72	0.0961	7226.625	7226.625	0.0961	0.0961
1-2-4-triethylbe	3186.105	0	3186.106	49.8727	3136.233	3136.233	0.2496	3135.983	3135.984	0.2496	0.2497
1-1-Bicyclohexyl	238.9565	0	238.9565	4.0338	234.9227	234.9227	0.035	234.8877	234.8877	0.035	0.035
Diphenyl	4383.133	0	4383.134	2.1702	4380.966	4380.966	6.4693	4374.497	4374.496	6.4693	6.4695
diamantane	8633.229	0	8633.231	174.8519	8458.38	8458.38	15.8027	8442.577	8442.577	15.8027	15.8052
Phenanthrene	6087.884	0	6087.887	0	6087.889	6087.889	2653.667	3434.22	3434.221	2653.668	2653.667
N-C15-CycloC5	291.442	0	291.442	0	291.4421	291.4421	3.1626	288.2794	288.2794	3.1626	3.1626
Chrysene	6120.283	0	6120.284	0	6120.288	6120.288	6120.288	0.0001	0.0001	6120.288	6120.286
1-Pentene	0	0	0	0	0	0	0	0	0	0	0
O-Xylene	0	0	0	0	0	0	0	0	0	0	0
Cyclopentane	0	0	0	0	0	0	0	0	0	0	0.0552
N-Pentadecane	0	0	0	0	0	0	0	0	0	0	0
N-Octadecane	0	0	0	0	0	0	0	0	0	0	0
Tetralin	0	0	0	0	0	0	0	0	0	0	0.0439
Ethylbenzene	0	0	0	0	0	0	0	0	0	0	0
Benzene	0	0	0	0	0	0	0	0	0	0	0
N-Butane	0	0	0	0	0	0	0	0	0	0	28.8114
Toluene	0	0	0	0	0	0	0	0	0	0	0
1-3-5-Mesitylene	0	0	0	0	0	0	0	0	0	0	0
P-Xylene	1732.494	0.3188	1732.176	1248.131	484.0454	484.0454	0.0088	484.0365	484.0366	0.0088	0.0088
N-Propylbenzene	0.0102	0	0.0102	0.0064	0.0038	0.0038	0	0.0038	0.0038	0	0
N-Butylbenzene	0	0	0	0	0	0	0	0	0	0	0
O-Ethyltoluene	0	0	0	0	0	0	0	0	0	0	0
C9H18	0	0	0	0	0	0	0	0	0	0	13.652
MthCyclohexane	0	0	0	0	0	0	0	0	0	0	38.0712

**Table A.3. (contd)**

Stream No.	510	511	515	523	524	526	529	531	532	536	540
Temp F	1247.858	402.8347	110	110	118.5025	110	110	109.9931	77	95	109.9931
Pres psig	1275	1275	1255	1255	1300	1255	1255	1	300	1300	1
Enth MMBtu/h	5.6979	-4.3021	-7.9143	-0.09247	-0.06215	-0.01709	-7.8047	-0.00062	-0.15399	-0.08641	-7.8041
Vapor mass fraction	1	0.6392	0.11945	1	1	1	0	1	1	1	0
Total lb/h	11010.12	11010.12	11010.12	1110	1110	205.1373	9694.978	0.9811	1100	1100	9694
Flowrates in lb/h											
Water	0	0	0	0	0	0	0	0	0	0	0
Hybrid Poplar Ch	0	0	0	0	0	0	0	0	0	0	0
Hydrogen	1219.721	1219.721	1219.77	1029.363	1029.363	190.2349	0.172	0.1702	1100	1100	0.0018
Carbon Dioxide	0	0	0	0	0	0	0	0	0	0	0
Methane	0	0	0	0	0	0	0	0	0	0	0
Ethane	0	0	0	0	0	0	0	0	0	0	0
Propane	0	0	0	0	0	0	0	0	0	0	0
I-Butane	0	0	0	0	0	0	0	0	0	0	0
2-5-Xylenol	0.0083	0.0083	0.0083	0.0001	0.0001	0	0.0083	0	0	0	0.0083
N-Heptane	0	0	0	0	0	0	0	0	0	0	0
1-ts-35-3C1CycC6	0.0016	0.0016	0.0016	0	0	0	0.0016	0	0	0	0.0016
3-3-5-TriMth-C7	0.0003	0.0003	0.0003	0	0	0	0.0003	0	0	0	0.0003
N-PropylCyc-C6	0.0087	0.0087	0.0087	0	0	0	0.0087	0	0	0	0.0087
1-2-3-Mesitylene	0.0191	0.0191	0.0191	0	0	0	0.0191	0	0	0	0.0191
N-ButylCycHexane	0.0016	0.0016	0.0016	0	0	0	0.0016	0	0	0	0.0016
1-2-DiC1-3C2-Bz	0.0871	0.0871	0.0871	0	0	0	0.0871	0	0	0	0.0871
Cis-Decalin	0.0984	0.0984	0.0984	0	0	0	0.0983	0	0	0	0.0983
Dimethyl-C11	0.0961	0.0961	0.0961	0	0	0	0.0961	0	0	0	0.0961
1-2-4-triethylbe	0.2497	0.2497	0.2497	0	0	0	0.2496	0	0	0	0.2496
1-1-Bicyclohexyl	0.035	0.035	0.035	0	0	0	0.035	0	0	0	0.035
Diphenyl	6.4695	6.4695	6.4695	0.0002	0.0002	0	6.4693	0	0	0	6.4693
diamantane	15.8052	15.8052	15.8052	0.0026	0.0026	0.0005	15.8022	0	0	0	15.8022
Phenanthrene	0	0	0	0	0	0	0	0	0	0	0
N-C15-CycloC5	0.0032	0.0032	0.0032	0	0	0	0.0032	0	0	0	0.0032
Chrysene	0	0	0	0	0	0	0	0	0	0	0
1-Pentene	0	0	0	0	0	0	0	0	0	0	0
O-Xylene	0	0	0	0	0	0	0	0	0	0	0
Cyclopentane	0.8451	0.8451	0.845	0.0552	0.0552	0.0102	0.7796	0.0006	0	0	0.779
N-Pentadecane	2.3923	2.3923	2.3923	0	0	0	2.3923	0	0	0	2.3923
N-Octadecane	0	0	0	0	0	0	0	0	0	0	0
Tetralin	196.8838	196.8838	196.8838	0.0439	0.0439	0.0081	196.8318	0.0004	0	0	196.8314
Ethylbenzene	0	0	0	0	0	0	0	0	0	0	0
Benzene	0	0	0	0	0	0	0	0	0	0	0
N-Butane	115.3507	115.3507	115.3013	28.8121	28.8121	5.3247	81.1645	0.2964	0	0	80.8681
Toluene	0	0	0	0	0	0	0	0	0	0	0
1-3-5-Mesitylene	0	0	0	0	0	0	0	0	0	0	0
P-Xylene	0.0088	0.0088	0.0088	0	0	0	0.0088	0	0	0	0.0088
N-Propylbenzene	0	0	0	0	0	0	0	0	0	0	0
N-Butylbenzene	0	0	0	0	0	0	0	0	0	0	0
O-Ethyltoluene	0	0	0	0	0	0	0	0	0	0	0
C9H18	6782.503	6782.503	6782.505	13.652	13.652	2.523	6766.33	0.1299	0	0	6766.2
MthCyclohexane	2669.528	2669.528	2669.527	38.0711	38.0711	7.0359	2624.419	0.3836	0	0	2624.036

**Table A.3. (contd)**

Stream No.	544	547	601	602	735	737	1850	1851			
Temp F	150	150	85.0536	85.0536	700.0002	496.55	90	105			
Pres psig	1	15	35	35	645	645	45.3041	40.3041			
Enth MMBtu/h	-21.85	-15.53	-39.134	-10.149	-28.903	-33.135	-129.5	-129.21			
Vapor mass fraction	0	0	0.98769	0.98769	1	1.00E-06	0	0			
Total lb/h	28555.25	38367.25	15824.14	4103.631	5193.402	5193.402	19029.97	19029.96			
Flowrates in lb/h											
Water	0	0	249.8139	64.7836	5193.402	5193.402	19029.97	19029.96			
Hybrid Poplar Ch	0	0	0	0	0	0	0	0			
Hydrogen	0.0018	0	457.8133	118.7234	0	0	0	0			
Carbon Dioxide	0	0	6947.662	1801.718	0	0	0	0			
Methane	0	0	2656.017	688.7776	0	0	0	0			
Ethane	0	0	1593.595	413.2626	0	0	0	0			
Propane	0	0	1340.26	347.5659	0	0	0	0			
I-Butane	0	0	1189.417	308.4483	0	0	0	0			
2-5-Xylenol	3162.44	4585.968	1.8125	0.47	0	0	0	0			
N-Heptane	1596.764	0	1332.604	345.5806	0	0	0	0			
1-ts-35-3C1CycC6	4541.518	316.1217	27.7666	7.2006	0	0	0	0			
3-3-5-TriMth-C7	1856.981	130.4455	5.7693	1.4961	0	0	0	0			
N-PropylCyc-C6	3903.079	975.7582	10.933	2.8352	0	0	0	0			
1-2-3-Mesitylene	128.3341	513.3166	0.2678	0.0695	0	0	0	0			
N-ButylCycHexane	125.9872	107.9704	0.193	0.05	0	0	0	0			
1-2-DiC1-3C2-Bz	135.2398	1457.493	0.3383	0.0877	0	0	0	0			
Cis-Decalin	1024.112	2160.371	1.5088	0.3913	0	0	0	0			
Dimethyl-C11	1406.674	7226.722	1.5272	0.3961	0	0	0	0			
1-2-4-triethylbe	49.8727	3136.233	0.253	0.0656	0	0	0	0			
1-1-Bicyclohexyl	4.0338	234.9227	0.0204	0.0053	0	0	0	0			
Diphenyl	2.1701	4380.964	0.0869	0.0225	0	0	0	0			
diamantane	174.8532	8458.38	1.6581	0.43	0	0	0	0			
Phenanthrene	0	3434.22	0.0042	0.0011	0	0	0	0			
N-C15-CycloC5	0	288.2826	0.0001	0	0	0	0	0			
Chrysene	0	0.0001	0	0	0	0	0	0			
1-Pentene	0	0	0	0	0	0	0	0			
O-Xylene	0	0	0	0	0	0	0	0			
Cyclopentane	0.779	0	0.0005	0.0001	0	0	0	0			
N-Pentadecane	0	2.3923	0	0	0	0	0	0			
N-Octadecane	0	0	0	0	0	0	0	0			
Tetralin	4.8831	191.9483	0.0003	0.0001	0	0	0	0			
Ethylbenzene	0	0	0	0	0	0	0	0			
Benzene	0	0	0	0	0	0	0	0			
N-Butane	80.868	0	0.2354	0.061	0	0	0	0			
Toluene	0	0	0	0	0	0	0	0			
1-3-5-Mesitylene	0	0	0	0	0	0	0	0			
P-Xylene	1248.139	484.0367	4.1775	1.0833	0	0	0	0			
N-Propylbenzene	0.0064	0.0038	0	0	0	0	0	0			
N-Butylbenzene	0	0	0	0	0	0	0	0			
O-Ethyltoluene	0	0	0	0	0	0	0	0			
C9H18	6484.484	281.7122	0.1032	0.0268	0	0	0	0			
MthCyclohexane	2624.033	0	0.3046	0.079	0	0	0	0			

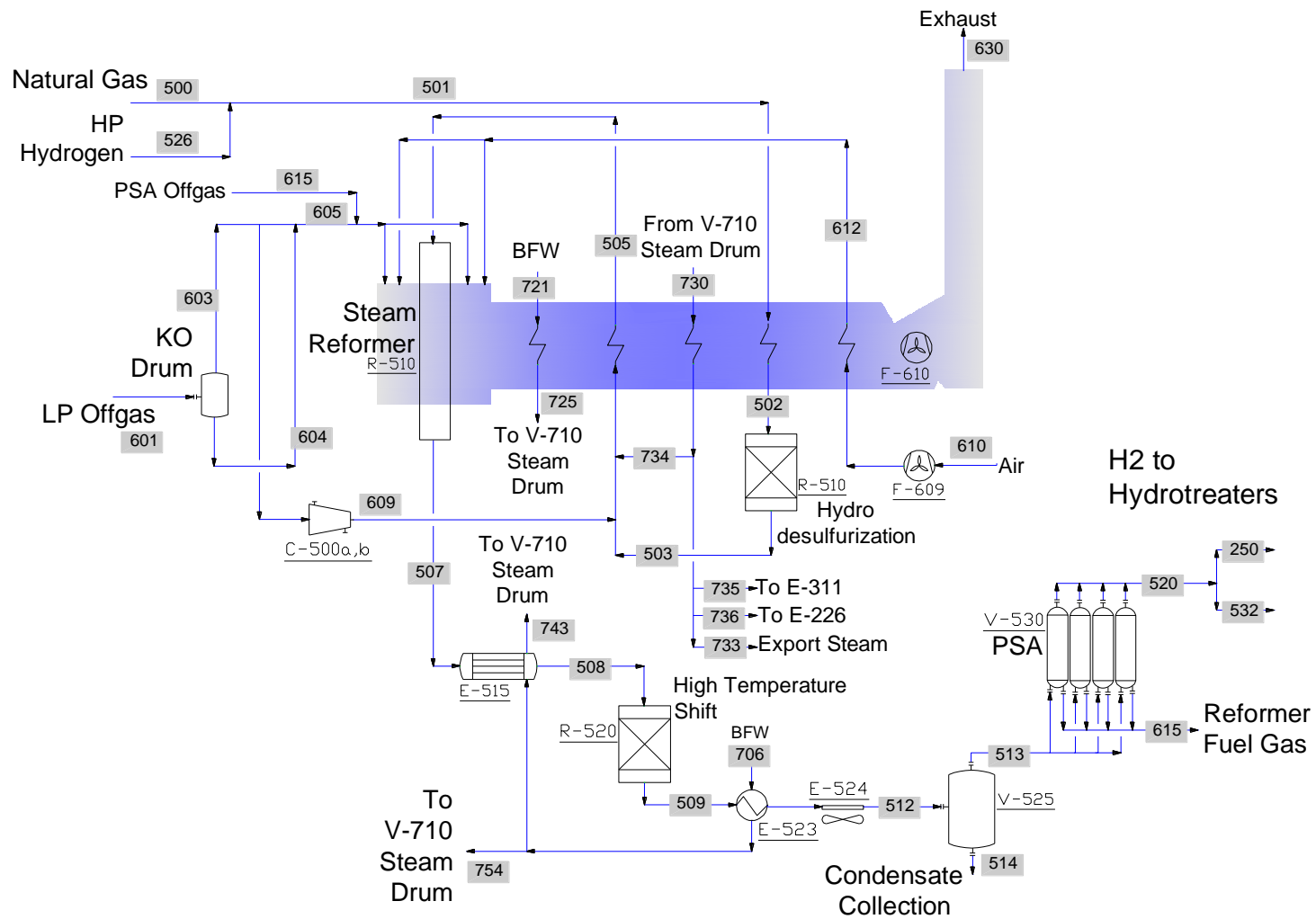

**Figure A.4.** Flow Diagram for Hydrogen Generation by Steam Reforming

**Table A.4. Hydrogen Generation by Steam Reforming Heat and Material Balance**

Stream No.	250	532	500	501	502	503	505	507	508	509	512
Temp F	77	77	60	61.8717	700	700	1050	1562	549.1881	667.5483	150
Pres psig	300	300	400	400	399.5	399.5	389.5	359.5	354.5	344.5	329.5
Enth MMBtu/h	-0.90996	-0.15399	-34.902	-34.892	-26.96	-26.96	-498.35	-367.68	-440.7	-440.7	-526.32
Vapor mass fraction	1	1	1	1	1	1	1	1	1	1	0.53835
Total lb/h	6500	1100	17196.06	17401.2	17401.2	17401.2	110098.3	110098.4	110098.4	110098.8	110098.8
Flowrates in lb/h											
Water	0	0	0	0	0	0	88044.1	60993.9	60993.9	51908.3	51908.3
Hydrogen	6500.0	1100.0	0.0	190.2	190.2	190.2	327.6	7450.3	7450.3	8466.9	8466.9
Carbon	0	0	0	0	0	0	0	0	0	0	0
Carbon Monoxide	0	0	0	0	0	0	0	17026.3	17026.3	2899.8	2899.8
Carbon Dioxide	0	0	0	0	0	0	2084.2	21749.5	21749.5	43945.3	43945.3
Methane	0	0	17196.1	17196.1	17196.1	17196.1	17992.9	2878.1	2878.1	2878.1	2878.1
Ethylene	0	0	0	0	0	0	0	0	0	0	0
Ethane	0	0	0	0	0	0	478.0	0.1	0.1	0.1	0.1
Propylene	0	0	0	0	0	0	0	0	0	0	0
Propane	0	0	0	0	0	0	401.9	0	0	0	0
I-Butane	0	0	0	0	0	0	356.5	0	0	0	0
Formaldehyde	0	0	0	0	0	0	0	0.2	0.2	0.2	0.2
2-5-Xylenol	0	0	0	0	0	0	0.1	0	0	0	0
N-Heptane	0	0	0	0	0	0	385.5	0	0	0	0
1-ts-35-3C1CycC6	0	0	0	0	0	0	6.9	0	0	0	0
3-3-5-TriMth-C7	0	0	0	0	0	0	1.3	0	0	0	0
N-PropylCyc-C6	0	0	0	0	0	0	2.6	0	0	0	0
1-2-3-Mesitylene	0	0	0	0	0	0	0	0	0	0	0
N-ButylCycHexane	0	0	0	0	0	0	0	0	0	0	0
1-2-DiC1-3C2-Bz	0	0	0	0	0	0	0	0	0	0	0
Cis-Decalin	0	0	0	0	0	0	0.2	0	0	0	0
Dimethyl-C11	0	0	0	0	0	0	0.1	0	0	0	0
1-2-4-triethylbe	0	0	0	0	0	0	0	0	0	0	0
1-1-Bicyclohexyl	0	0	0	0	0	0	0	0	0	0	0
Diphenyl	0	0	0	0	0	0	0	0	0	0	0
diamantane	0	0	0	0	0	0	0.1	0	0	0	0
Phenanthrene	0	0	0	0	0	0	0	0	0	0	0
N-C15-CycloC5	0	0	0	0	0	0	0	0	0	0	0
Cyclopentane	0	0	0	0	0	0	0	0	0	0	0
N-Pentadecane	0	0	0	0	0	0	0	0	0	0	0
N-Octadecane	0	0	0	0	0	0	0	0	0	0	0
Tetralin	0	0	0	0	0	0	0	0	0	0	0
Ethylbenzene	0	0	0	0	0	0	0	0	0	0	0
Benzene	0	0	0	0	0	0	0	0	0	0	0
N-Butane	0	0	0	5.3	5.3	5.3	5.4	0	0	0	0
Toluene	0	0	0	0	0	0	0	0	0	0	0
1-3-5-Mesitylene	0	0	0	0	0	0	0	0	0	0	0
P-Xylene	0	0	0	0	0	0	1.1	0	0	0	0
C9H18	0	0	0	2.5	2.5	2.5	2.5	0	0	0	0
MthCyclohexane	0	0	0	7.0	7.0	7.0	7.1	0	0	0	0

**Table A.4. (contd)**

Stream No.	513	514	520	526	601	603	604	605	609	610	612
Temp F	150	150	150	110	85.0536	85.0536	85.0536	85.0536	256.2011	60	550
Pres psig	329.5	329.5	329.5	1255	35	35	35	35	400	0.001	2
Enth MMBtu/h	-183.1	-343.22	1.9013	0.009921	-39.131	-38.37	-0.76068	-26.859	-11.172	-0.97388	26.657
Vapor mass fraction	1	0	1	1	0.98944	1	0	1	1	1	1
Total lb/h	59271.69	50827.07	7620.208	205.1373	15824.14	15657.06	167.0814	10959.94	4697.12	230000	230000
Flowrates in lb/h											
Water	1081.2	50827.1	0	0	249.8	147.0	102.8	102.9	44.1	0	0
Hydrogen	8466.9	0	7620.2	190.2	457.8	457.8	0.0	320.5	137.3	0	0
Carbon	0.0	0	0	0	0	0	0	0	0	0	0
Carbon Monoxide	2899.8	0	0	0	0	0	0	0	0	0	0
Carbon Dioxide	43945.3	0	0	0	6947.7	6947.3	0.4	4863.1	2084.2	0	0
Methane	2878.1	0	0	0	2656.0	2656.0	0.0	1859.2	796.8	0	0
Ethylene	0	0	0	0	0	0	0	0	0	0	0
Ethane	0.1	0	0	0	1593.6	1593.4	0.1	1115.4	478.0	0	0
Propylene	0	0	0	0	0	0	0	0	0	0	0
Propane	0	0	0	0	1340.3	1339.8	0.4	937.9	401.9	0	0
I-Butane	0	0	0	0	1189.4	1188.5	1.0	831.9	356.5	0	0
Formaldehyde	0.2	0	0	0	0	0	0	0	0	0	0
2-5-Xylenol	0.0	0	0	0	1.8	0.4	1.4	0.3	0.1	0	0
N-Heptane	0	0	0	0	1332.6	1285.0	47.6	899.5	385.5	0	0
1-ts-35-3C1CycC6	0	0	0	0	27.8	23.1	4.7	16.1	6.9	0	0
3-3-5-TriMth-C7	0	0	0	0	5.8	4.3	1.5	3.0	1.3	0	0
N-PropylCyc-C6	0	0	0	0	10.9	8.7	2.3	6.1	2.6	0	0
1-2-3-Mesitylene	0	0	0	0	0.3	0.2	0.1	0.1	0	0	0
N-ButylCycHexane	0	0	0	0	0.2	0.1	0.1	0.1	0	0	0
1-2-DiC1-3C2-Bz	0	0	0	0	0.3	0.1	0.2	0.1	0	0	0
Cis-Decalin	0	0	0	0	1.5	0.7	0.8	0.5	0.2	0	0
Dimethyl-C11	0	0	0	0	1.5	0.2	1.3	0.1	0.1	0	0
1-2-4-triethylbe	0	0	0	0	0.3	0	0.2	0	0	0	0
1-1-Bicyclohexyl	0	0	0	0	0.0	0	0	0	0	0	0
Diphenyl	0	0	0	0	0.1	0	0.1	0	0	0	0
diamantane	0	0	0	0	1.7	0.3	1.4	0.2	0.1	0	0
Phenanthrene	0	0	0	0	0	0	0	0	0	0	0
N-C15-CycloC5	0	0	0	0	0	0	0	0	0	0	0
Cyclopentane	0	0	0	0	0	0	0	0	0	0	0
N-Pentadecane	0	0	0	0	0	0	0	0	0	0	0
N-Octadecane	0	0	0	0	0	0	0	0	0	0	0
Tetralin	0	0	0	0	0	0	0	0	0	0	0
Ethylbenzene	0	0	0	0	0	0	0	0	0	0	0
Benzene	0	0	0	0	0	0	0	0	0	0	0
N-Butane	0	0	0	5.3	0.2	0.2	0.0	0.2	0.1	0	0
Toluene	0	0	0	0	0	0	0	0	0	0	0
1-3-5-Mesitylene	0	0	0	0	0	0	0	0	0	0	0
P-Xylene	0	0	0	0	4.2	3.6	0.6	2.5	1.1	0	0
C9H18	0	0	0	2.5	0.1	0.1	0	0.1	0	0	0
MthCyclohexane	0	0	0	7.0	0.3	0.3	0	0.2	0.1	0	0

**Table A.4. (contd)**

Stream No.	615	630	706	707	721	725	730	733	734	735	736
Temp F	150	311.6723	276.468	276.468	497.3775	497.3795	497.3795	700.0002	700	700	700
Pres psig	329.5	1.5	670	670	650	650	650	645	645	645	645
Enth MMBtu/h	-185.86	-447.3	-1133.3	-0.00703	-1371.1	-1316.6	-675.88	-121.47	-486.09	-28.903	-22.468
Vapor mass fraction	0.98557	1	0	0	0	0.355	1	1	1	1	1
Total lb/h	51651.48	292778.2	171067	1.0604	214800.3	214800	119221.6	21991.57	88000	5193	4037
Flowrates in lb/h											
Water	1081.2	28603.1	171067.0	1.1	214800.3	214800.0	119221.6	21991.6	88000	5193.0	4037.0
Hydrogen	846.7	0	0	0	0	0	0	0	0	0	0
Carbon	0	0	0	0	0	0	0	0	0	0	0
Carbon Monoxide	2899.8	0	0	0	0	0	0	0	0	0	0
Carbon Dioxide	43945.3	78010.5	0	0	0	0	0	0	0	0	0
Methane	2878.1	0	0	0	0	0	0	0	0	0	0
Ethylene	0	0	0	0	0	0	0	0	0	0	0
Ethane	0.1	0	0	0	0	0	0	0	0	0	0
Propylene	0	0	0	0	0	0	0	0	0	0	0
Propane	0	0	0	0	0	0	0	0	0	0	0
1-Butane	0	0	0	0	0	0	0	0	0	0	0
Formaldehyde	0	0	0	0	0	0	0	0	0	0	0
2-5-Xylenol	0	0	0	0	0	0	0	0	0	0	0
N-Heptane	0	0	0	0	0	0	0	0	0	0	0
1-ts-35-3C1CycC6	0	0	0	0	0	0	0	0	0	0	0
3-3-5-TriMth-C7	0	0	0	0	0	0	0	0	0	0	0
N-PropylCyc-C6	0	0	0	0	0	0	0	0	0	0	0
1-2-3-Mesitylene	0	0	0	0	0	0	0	0	0	0	0
N-ButylCycHexane	0	0	0	0	0	0	0	0	0	0	0
1-2-DiC1-3C2-Bz	0	0	0	0	0	0	0	0	0	0	0
Cis-Decalin	0	0	0	0	0	0	0	0	0	0	0
Dimethyl-C11	0	0	0	0	0	0	0	0	0	0	0
1-2-4-triethylbe	0	0	0	0	0	0	0	0	0	0	0
1-1-Bicyclohexyl	0	0	0	0	0	0	0	0	0	0	0
Diphenyl	0	0	0	0	0	0	0	0	0	0	0
diamantane	0	0	0	0	0	0	0	0	0	0	0
Phenanthrene	0	0	0	0	0	0	0	0	0	0	0
N-C15-CycloC5	0	0	0	0	0	0	0	0	0	0	0
Cyclopentane	0	0	0	0	0	0	0	0	0	0	0
N-Pentadecane	0	0	0	0	0	0	0	0	0	0	0
N-Octadecane	0	0	0	0	0	0	0	0	0	0	0
Tetralin	0	0	0	0	0	0	0	0	0	0	0
Ethylbenzene	0	0	0	0	0	0	0	0	0	0	0
Benzene	0	0	0	0	0	0	0	0	0	0	0
N-Butane	0	0	0	0	0	0	0	0	0	0	0
Toluene	0	0	0	0	0	0	0	0	0	0	0
1-3-5-Mesitylene	0	0	0	0	0	0	0	0	0	0	0
P-Xylene	0	0	0	0	0	0	0	0	0	0	0
C9H18	0	0	0	0	0	0	0	0	0	0	0
MthCyclohexane	0	0	0	0	0	0	0	0	0	0	0

**Table A.4. (contd)**

Stream No.	743	754
Temp F	499.8419	400
Pres psig	665	665
Enth MMBtu/h	-501.74	-536.23
Vapor mass fraction	1	0
Total lb/h	88500	82567.1
Flowrates in lb/h		
Water	88500.0	82567.1
Hydrogen	0	0
Carbon	0	0
Carbon Monoxide	0	0
Carbon Dioxide	0	0
Methane	0	0
Ethylene	0	0
Ethane	0	0
Propylene	0	0
Propane	0	0
I-Butane	0	0
Formaldehyde	0	0
2-5-Xylenol	0	0
N-Heptane	0	0
1-ts-35-3C1CycC6	0	0
3-3-5-TriMth-C7	0	0
N-PropylCyc-C6	0	0
1-2-3-Mesitylene	0	0
N-ButylCycHexane	0	0
1-2-DiC1-3C2-Bz	0	0
Cis-Decalin	0	0
Dimethyl-C11	0	0
1-2-4-triethylbe	0	0
1-1-Bicyclohexyl	0	0
Diphenyl	0	0
diamantane	0	0
Phenanthrene	0	0
N-C15-CycloC5	0	0
Cyclopentane	0	0
N-Pentadecane	0	0
N-Octadecane	0	0
Tetralin	0	0
Ethylbenzene	0	0
Benzene	0	0
N-Butane	0	0
Toluene	0	0
1-3-5-Mesitylene	0	0
P-Xylene	0	0
C9H18	0	0
MthCyclohexane	0	0

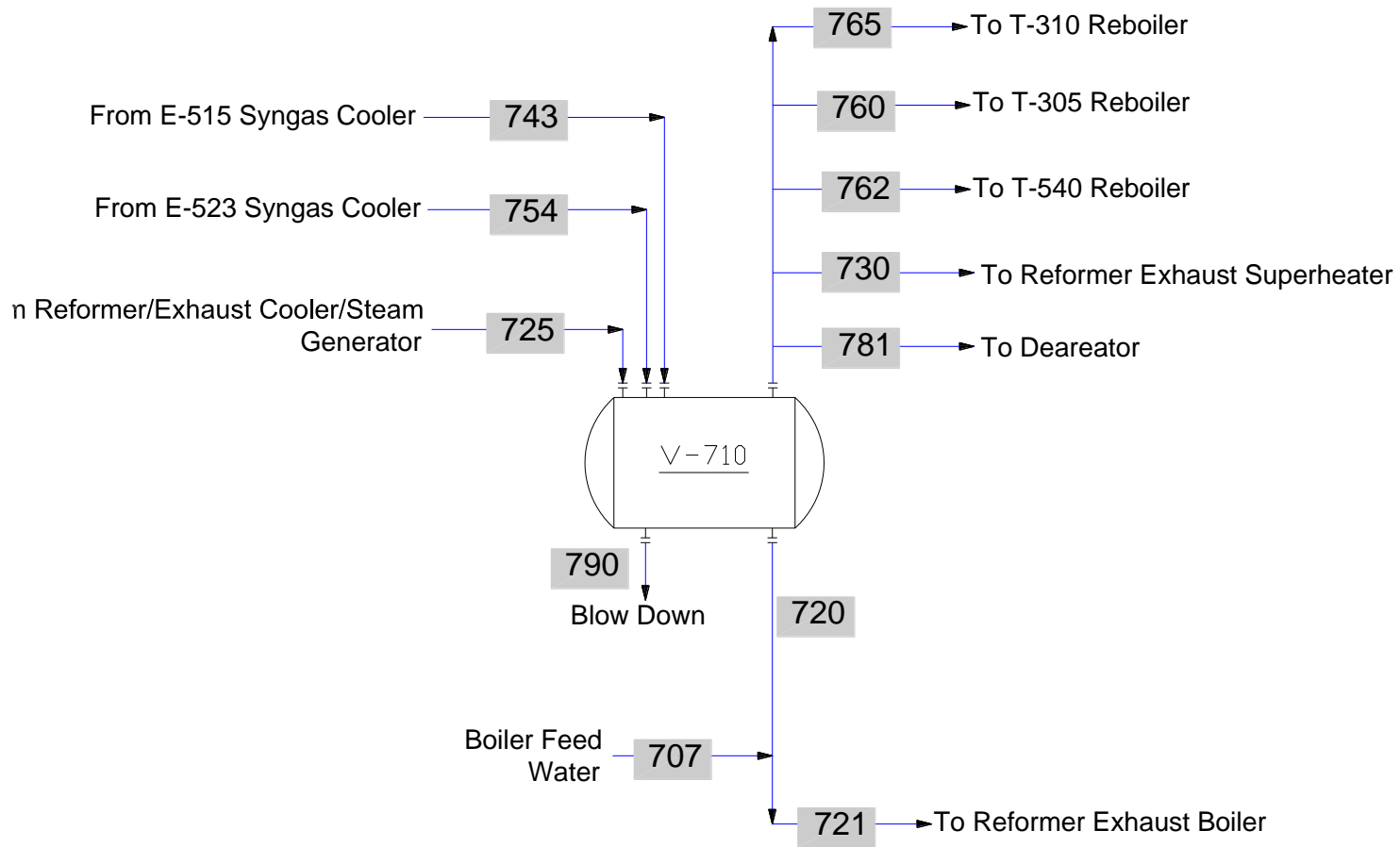
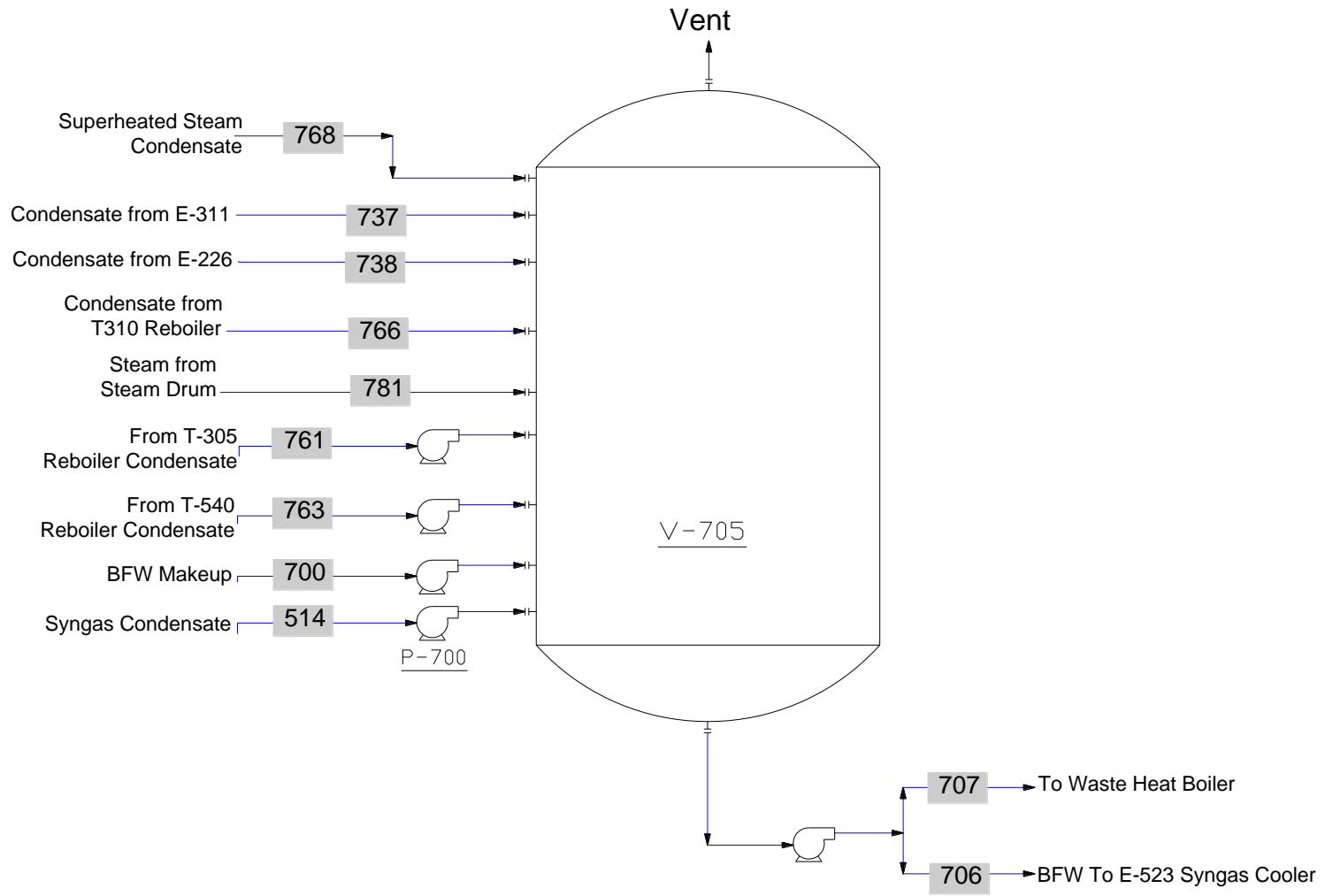

**Figure A.5.** Flow Diagram for the Steam Reformer Steam Drum

**Table A.5.** Steam Reformer Steam Drum Heat and Material Balance

Stream No.	707	720	721	725	730	743
Temp F	276.5	497.4	497.4	497.4	497.4	499.8
Pres psig	670	650	650	650	650	665
Enth MMBtu/h	-0.007	-1371.1	-1371.1	-1316.6	-675.88	-501.74
Vapor mass fraction	0	0	0	0.355	1	1
Total lb/h	1.1	214799.2	214800.3	214800.0	119221.6	88500.0
Flowrates in lb/h						
Water	1.1	214799.2	214800.3	214800.0	119221.6	88500.0

Stream No.	754	760	762	765	781	790
Temp F	400.0	497.4	497.4	497.4	497.4	497.4
Pres psig	665	650	650	650	650	650
Enth MMBtu/h	-536.23	-91.839	-21.543	-23.81	-47.62	-122.87
Vapor mass fraction	0	1	1	1	1	0
Total lb/h	82567.1	16200.0	3800.0	4200.0	8400.0	19250.0
Flowrates in lb/h						
Water	82567.1	16200.0	3800.0	4200.0	8400.0	19250.0



**Figure A.6.** Flow Diagram for Condensate Collection

**Table A.6. Condensate Collection Heat and Material Balance**

Stream No.	514	700	706	707	737	738
Temp F	150.0	60.0	276.5	276.5	496.6	496.6
Pres psig	329.5	20	670	670	645	645
Enth MMBtu/h	-343.22	-386.06	-1133.3	-0.0070253	-33.135	-25.758
Vapor mass fraction	0	0	0	0	1.00E-06	1.00E-06
Total lb/h	50827.1	56419.0	171067.0	1.1	5193.4	4037.1
Flowrates in lb/h						
Water	50827.1	56419.0	171067.0	1.1	5193.4	4037.1

Stream No.	761	763	766	768	781	
Temp F	495.6	497.4	496.6	366.0	497.4	
Pres psig	645	650	645	150	650	
Enth MMBtu/h	-103.44	-24.193	-26.71	-143.64	-47.62	
Vapor mass fraction	0	0.023151	0.034147	0	1	
Total lb/h	16200.0	3800.0	4200.0	21992.0	8400.0	
Flowrates in lb/h						
Water	16200.0	3800.0	4200.0	21992.0	8400.0	



## **Appendix B**

### **Equipment Cost Details**



## **Appendix B**

### **Equipment Cost Details**

Table B.1 lists the equipment cost details. Table B.2 lists the specifications for the standard equipment.



**Table B.1. (contd)**

# Reqd	Equipment Name	Original Stream Metric	New Stream Metric	Scaling units	Size Ratio	Original Equip Cost (per unit)	Base Year	Scaling Exp	Install Factor	Scaled and Installed Cost in Base Year	Installed Cost in 2007\$	Bare Equip cost in 2007\$	Equip Cost Source
<b>A300/500 Hydrocracking and Separations</b>													
1	T-305 Debutanizer	69,495	69,495	lb/h	1.00	\$55,100	1Q 2007	0.65	2.47	217,113	222,238	\$89,975	3
1	T-310 Naphtha Splitter	70,500	66,028	lb/h	0.94	\$183,700	1Q 2005	0.65	2.47	434,817	488,894	\$197,933	3
1	T-315 Diesel Splitter	45,548	46,668	lb/h	1.02	\$65,500	1Q 2005	0.65	2.47	164,360	184,801	\$74,818	3
1	T-540	9,680	9,694	lb/h	1.00	\$123,800	1Q 2005	0.65	2.47	306,073	344,139	\$139,327	3
1	T-305 Debutanizer Reboiler	11.60	11.60	mmbtuh	1.00	\$48,600	1Q 2007	0.65	2.47	120,042	122,876	\$49,747	3
1	T-310 Reboiler	2.90	2.90	mmbtuh	1.00	\$27,200	1Q 2007	0.65	2.47	67,184	68,770	\$27,842	3
1	T-315 Reboiler	4.77	10.20	mmbtuh	2.14	\$24,900	1Q 2005	0.65	2.47	100,797	113,333	\$45,884	3
1	T-540 Reboiler	2.63	2.63	mmbtuh	1.00	\$22,400	1Q 2007	0.65	2.47	55,328	56,634	\$22,929	3
1	T-305 Debutanizer Condenser	1.48	1.48	mmbtuh	1.00	\$33,200	1Q 2007	0.65	2.47	82,004	83,940	\$33,984	3
1	T-310 Condenser	5.62	5.62	mmbtuh	1.00	\$43,200	1Q 2007	0.65	2.47	106,704	109,223	\$44,220	3
1	T-315 Condenser	13.40	13.40	mmbtuh	1.00	\$55,800	1Q 2007	0.65	2.47	137,826	141,079	\$57,117	3
1	T-540 Condenser	2.65	2.65	mmbtuh	1.00	\$79,300	1Q 2007	0.65	2.47	195,871	200,495	\$81,172	3
1	T-305 Reflux Drum	3655	3466	lb/h	0.95	\$7,000	1Q 2005	0.65	2.47	16,703	18,781	\$7,604	3
1	T-310 Reflux Drum	55	49	gpm	0.88	\$17,500	1Q 2005	0.65	2.47	39,832	44,786	\$18,132	3
1	T-315 Reflux Drum	82	89	gpm	1.08	\$16,500	1Q 2005	0.65	2.47	42,890	48,224	\$19,524	3
1	T-540 Reflux Drum	24	23	gpm	0.96	\$11,500	1Q 2005	0.65	2.47	27,630	31,066	\$12,577	3
1	Debutanizer Feed Preheater	6.66	3.29	mmbtuh	0.49	\$29,000	1Q 2005	0.65	2.47	45,291	50,924	\$20,617	3
1	T315 Feed Preheater	6.66	4.23	mmbtuh	0.64	\$29,000	1Q 2005	0.65	2.47	53,328	59,961	\$24,276	3
1	Hydrocracker Unit :	2,250	590	bpd fd	0.26	\$30,000,000	1Q 2005	0.65	2.47	12,567,718	14,130,726	\$5,720,942	4
	H508 Fired heater	Included in hydrocracker unit cost											
	R510 Hydrocracker Vessel	Included in hydrocracker unit cost											
	E513 Feed/product exchanger	Included in hydrocracker unit cost											
	E516 air cooler	Included in hydrocracker unit cost											
	E517 trim cooler	Included in hydrocracker unit cost											
	V520 HP flash	Included in hydrocracker unit cost											
	V530 LP flash	Included in hydrocracker unit cost											
1	Naphtha Product Cooler	1.4	1.45	mmbtuh	1.04	\$46,300	1Q 2005	0.65	2.47	116,999	131,550	\$53,259	3
1	Diesel Product Cooler	3.1	4.93	mmbtuh	1.59	\$44,600	1Q 2005	0.65	2.47	148,935	167,458	\$67,797	3
											16,819,896	6,809,675	
							Subtotal				\$2,522,984	\$1,021,451	
							15%				<b>\$19,342,881</b>	<b>\$7,831,126</b>	
Cost sources 3) Aspen Icarus; 4) Marker et al. 2005													

**Table B.1. (contd)**

# Reqd	Equipment Name	Original Stream Metric	New Stream Metric	Scaling units	Size Ratio	Original Equip Cost (per unit)	Base Year	Scaling Exp	Install Factor	Scaled and Installed Cost in Base Year	Installed Cost in 2007\$	Bare Equip cost in 2007\$	Equip Cost Source
<b>A 700 Utilities and Auxiliaries</b>													
1	Wastewater treatment incinerator	1,000	0	tpd	0.00	\$442,000	2004	1,000	2.47	0	0	\$0	5
1	WWT anaerobic/aerobic digestion	1,000	2,000	tpd	2.00	\$1,554,000	2004	1,000	2.47	2,438,487	2,884,336	\$1,167,747	5
1	Wastewater storage	593,849	672,840	gallons	1.13	226,710	1Q 2005	593,849		607,324	682,855	\$276,459	
1	Field-Erected CTW w/pumps, etc	10,400	7,549	gpm	0.73	\$352,000	1Q 2005	0.78	2.47	274,164	308,261	\$124,802	3
1	Plant Air Compressor	2,000	2,000	tpd	1.00	\$32,376	2002	0.34	2.47	79,969	106,212	\$43,001	6
1	Hydraulic Truck Dump with Scale	2,000	2,000	tpd	1.00	\$80,000	1998	0.6	2.47	197,600	266,553	\$107,916	6
1	Firewater Pump	2,000	2,000	tpd	1.00	\$18,400	1997	0.79	2.47	45,448	61,783	\$25,013	6
1	Diesel Pump	2,000	2,000	tpd	1.00	\$6,100	1997	0.79	2.47	15,067	20,482	\$8,292	6
1	Instrument Air Dryer	2,000	2,000	tpd	1.00	\$8,349	2002	0.6	2.47	20,622	27,389	\$11,089	6
1	Plant Air Receiver	2,000	2,000	tpd	1.00	\$7,003	2002	0.72	2.47	17,297	22,974	\$9,301	6
1	Firewater Storage Tank	2,000	2,000	tpd	1.00	\$166,100	1997	0.51	2.47	410,267	557,726	\$225,800	6
1	Ammonia Pump	included in Stream Reformer Cost											
1	Hydrazine Pump	included in Stream Reformer Cost											
1	Ammonia Storage Tank	included in Stream Reformer Cost											
1	Hydrazine Storage Tank	included in Stream Reformer Cost											
1	Flare	included in Stream Reformer Cost											
1	Feed Storage	1,056,846	1,056,846	gallons	1.00	470,000	1Q 2005	0.65	2.47	1,160,900	1,305,278	\$528,452	3
1	Product Storage	558,000	681,114	gallons	1.22	320,384	1Q 2005	0.65	2.47	836,744	940,807	\$380,894	3
1	Product Storage	558,000	712,728	gallons	1.28	320,384	1Q 2005	0.65	2.47	930,580	1,046,313	\$423,609	3
							Subtotal				\$8,230,968	\$3,332,376	
	Equipment Contingency						15%				\$1,234,645	\$499,856	
											<b>\$9,465,613</b>	<b>\$3,832,232</b>	

Cost sources 3) Aspen Icarus; 5) Beckman et al. 1990; 6) Phillips et al. 2007

**Table B.1. (contd)**

# Reqd	Equipment Name	Original Stream Metric	New Stream Metric	Scaling units	Size Ratio	Original Equip Cost (per unit)	Base Year	Scaling Exp	Install Factor	Scaled and Installed Cost in Base Year	Total Project Investment	Equip Cost Source
<b>A 600 Hydrogen Plant</b>												
1	Steam Reformer System w/ associated OSBL	24.5	34.4	mmscf H2	1.40	\$69,900,000	May 2007	0.65	2.47	87,152,973	86,106,854	7
							Subtotal			87,152,973	86,106,854	
	Equipment Contingency						0%			0	0	
										87,152,973	86,106,854	
Cost sources 7) SRI 2007												

**Table B.2.** Standard Equipment Specifications

Tag	Description	T, °F	P, psig	Type and Size			Metallurgy
R-205	1 <sup>st</sup> stage Reactor	750	2530		Diameter, ft	8	316 SS clad
					Length, ft	41	
R-215	2 <sup>nd</sup> stage Reactor	780	2530		Diameter, ft	16	316 SS clad
					Length, ft	80	
V-222	Three-Phase Separator	100	700		Diameter, ft	10	316 SS
					Length, ft	58	
E-202	1 <sup>st</sup> Feed/Product Heat Exchanger	750	2530	Shell & tube floating head	Area, ft <sup>2</sup>	6712	316 SS
					Duty, MMBtu/h	59.9	
E-206	2 <sup>nd</sup> Feed/Product Heat Exchanger	750	2530	Shell & tube floating head	Area, ft <sup>2</sup>	6518	316 SS
					Duty, MMBtu/h	33.3	
H-210	Fired Heater	850	2530		Duty, MMBtu/h	8.18	316 SS
E-220	Air Cooler	400	750	Air Fin	Area, ft <sup>2</sup>	6170	316 SS
					Duty, MMBtu/h	40.4	
E-221	Product Trim Cooler	150	700	Shell & tube floating head	Area, ft <sup>2</sup>	3589	316 SS
					Duty, MMBtu/h	8.35	
V-225	Product Flash Drum	100	100		Diameter, ft	7	316 SS
					Length, ft	21	
C-250	Hydrogen Compressor	300 inlet		Reciprocating motor drive	3 stage	2480 acfm	
T-305	Debutanizer	50	440		Diameter, ft	5	CS
					# trays	18	
T-310	Naphtha Splitter	50	500		Diameter, ft	3	CS
					# trays	28	
T-315	Diesel Splitter	50	700		Diameter, ft	5	CS
					# trays	8	
T-540	T-540	50	400		Diameter, ft	3	CS
					# trays	28	
T-305	Debutanizer Reboiler	150	750	Shell & tube floating head	Area, ft <sup>2</sup>	975	Tubes 316/ CS Shell
					Duty, MMBtu/h	11.6	
E-310R	Reboiler	150	700	Shell & tube floating head	Area, ft <sup>2</sup>	224	Tubes 316/ CS Shell
					Duty, MMBtu/h	2.9	
E-315R	Reboiler	150	500	Shell & tube floating head	Area, ft <sup>2</sup>	218	Tubes 316/ CS Shell
					Duty, MMBtu/h	4.7	
E-540R	Reboiler	150	880	Shell & tube floating head	Area, ft <sup>2</sup>	127	Tubes 316/ CS Shell
					Duty, MMBtu/h	2.63	

**Table B.2.** (contd)

E-305C	Debutanizer Condenser	150	200	Air Fin	Area, ft <sup>2</sup> Duty, MMBtu/h	209 1.5	CS Tubes
E-310C	Naphtha Splitter Condenser	150	200	Air Fin	Area, ft <sup>2</sup> Duty, MMBtu/h	503 5.6	CS Tubes
E-315C	Diesel Splitter Condenser	150	300	Air Fin	Area, ft <sup>2</sup> Duty, MMBtu/h	670 13.4	CS Tubes
E-540C	T-540 Condenser	150	400	Air Fin	Area, ft <sup>2</sup> Duty, MMBtu/h	1680 2.7	CS Tubes
D-305	Debutanizer Reflux Drum	15	250	Horizontal, 5 min holdup	Diameter, ft Length, ft	2 6	CS
D-310	Naphtha Splitter Reflux Drum	15	350	Horizontal, 5 min holdup	Diameter, ft Length, ft	4.8 14.3	CS
D-315	Diesel Splitter Reflux Drum	15	425	Horizontal, 5 min holdup	Diameter, ft Length, ft	4.5 13.5	CS
D-540	T-540 Reflux Drum	15	250	Horizontal, 5 min holdup	Diameter, ft Length, ft	3.4 10.3	CS
E-305	Debutanizer Feed Preheater	150	530	Pre-engineered	Area, ft <sup>2</sup> Duty, MMBtu/h	83 3.33	CS
E-311	Diesel Splitter Feed Preheater	150		Shell & tube floating head	Area, ft <sup>2</sup> Duty, MMBtu/h	574 3.55	CS
E-542	Naphtha Product Cooler	50	475	Air Fin	Area, ft <sup>2</sup> Duty, MMBtu/h	838	CS
E-543	Diesel Product Cooler	50	475	Air Fin	Area, ft <sup>2</sup> Duty, MMBtu/h	670 3.1	CS







**Pacific Northwest**  
NATIONAL LABORATORY

902 Battelle Boulevard  
P.O. Box 999  
Richland, WA 99352  
1-888-375-PNNL (7665)

[www.pnl.gov](http://www.pnl.gov)



U.S. DEPARTMENT OF  
**ENERGY**